

RoHS Compliant

REVISIONS			
REV.	DESCRIPTION	DATE	DESIGN

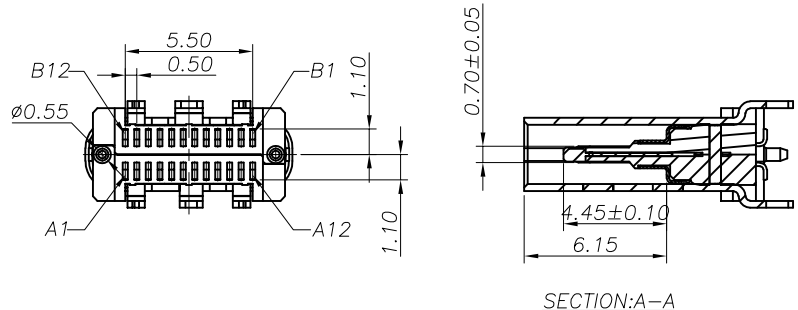
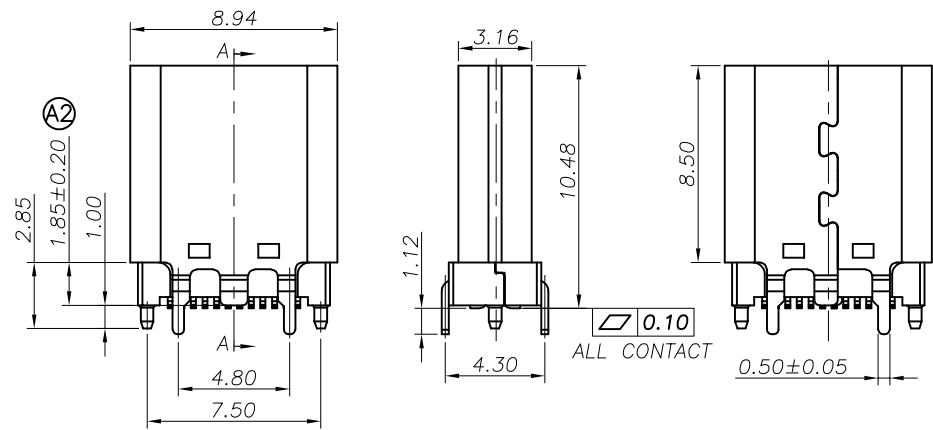
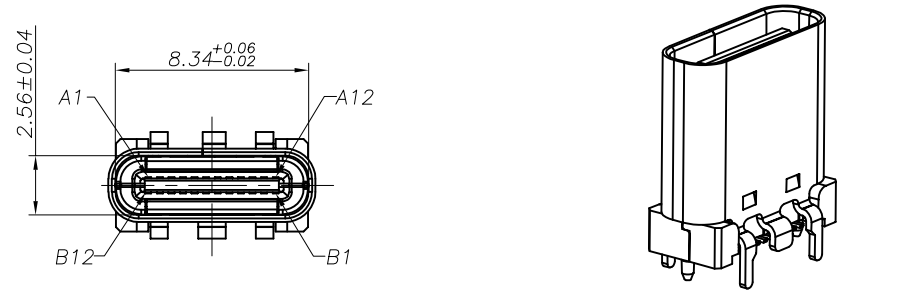

NOTE:

- MATERIAL SPECIFICATION:
 - HOUSING: LCP, UL94 V-0.
 - TERMINAL: COPPER ALLOY
 - MID PLATE: STAINLESS STEEL
 - FRONT SHELL: STAINLESS STEEL
 - EMI PLATE: STAINLESS STEEL
- PLATING SPECIFICATION:
 - TERMINAL:
 - Ni 50u" MIN. UNDER PLATED OVER ALL.
 - Au PLATED ON THE FUNCTIONAL AREA OF CONTACT. (GOLD PLATING THICKNESS FOLLOW THE P/N)
 - PLATING SPECIFICATIONS OF THE SOLDER AREA FOLLOW THE P/N
 - FRONT SHELL:
 - PLATING SPECIFICATIONS FOLLOW THE P/N
 - MID PLATE&EMI PLATE:
 - CLEAR ONLY
- MECHANICAL PERFORMANCE,
 - INSERTION FORCE: 0.5~2.0kgf.
 - REMOVAL FORCE: 0.8kgf~2.0kgf.
 - DURABILITY: 10000 CYCLES.
- ELECTRICAL PERFORMANCE,
 - VOLTAGE RATING: 5 V DC/AC (RMS. max)
CURRENT RATING: 5 AMPS. FOR TOTAL VBUS/GND PINS;
1.25AMPS FOR CC PIN, 0.25 AMPS. FOR ALL OTHER CONTACT.
 - LLCR:
 - VBUS & GND PINS AND OTHER PINS: 40mΩ/PIN MAX.
 - SHIELD: 50mΩ/MAX.
 - LLCR MAX. CHANGE OF ALL PINS: 10mΩ.
 - INSULATION RESISTANCE: 100MΩ MIN
 - DIELECTRIC WITHSTAND VOLTAGE, AC 100V FOR 1 MINUTE.
- ENVIRONMENTAL PERFORMANCE:
 - OPERATING TEMPERATURE: -25°C~+85°C.
- IR REFLOW:
 - THE PEAK TEMPERATURE ON THE BOARD SHALL BE MAINTAINED FOR 10 SECONDS AT 260°C.

PART NO. INFORMATION

U06-C F X X 5 X - 088 - V2

PORT TYPE
C: TYPE C

GENDER
F: FEMALE
M: MALE

CONTACT PLATED
1: GOLD FLASH
2: GOLD 3U"
3: GOLD 5U"
4: GOLD 10U"
5: GOLD 15U"
6: GOLD 30U"

PACKAGE
T: TRAY R: TAPE REEL

HOUSING COLOR
2: WHITE
5: BLACK
9: NATURE

HOUSING MATERIAL
A: LCP B: PBT
C: PA9T D: PA6T
E: PA46 F: PA66

Bestcreate Technology Limited

TOLERANCES UNLESS OTHERWISE SPECIFIED:

.X	± 0.30	X.	± 10'
.XX	± 0.20	.XX'	± 8'
.XXX	± 0.10	.XXX'	± 5'

Website: www.bsc-elec.com
Email: bestcreate@bsc-elec.com

DESIGN: I. L	DATE:
CHECKED: C. W	DATE:
APPROVED: C. W	DATE:

TITLE: TYPE CF 24P VERTICAL (H=10.50) TAIL LENGTH: 1.15MM		
MATERILA:	PART NO: U06-CFXX5X-088-V2	SIZE: A4
FINSH:	DWG NO: U06-CFXX5X-088-V2	1 OF 3

REV: A	UNIT mm	SCALE 1=1	QUALITY SYMBOLS
-----------	------------	--------------	-----------------

RoHS Compliant

REVISIONS			
REV.	DESCRIPTION	DATE	DESIGN

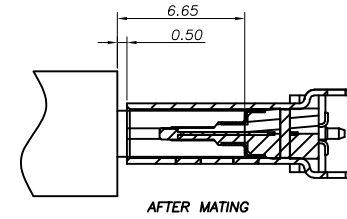
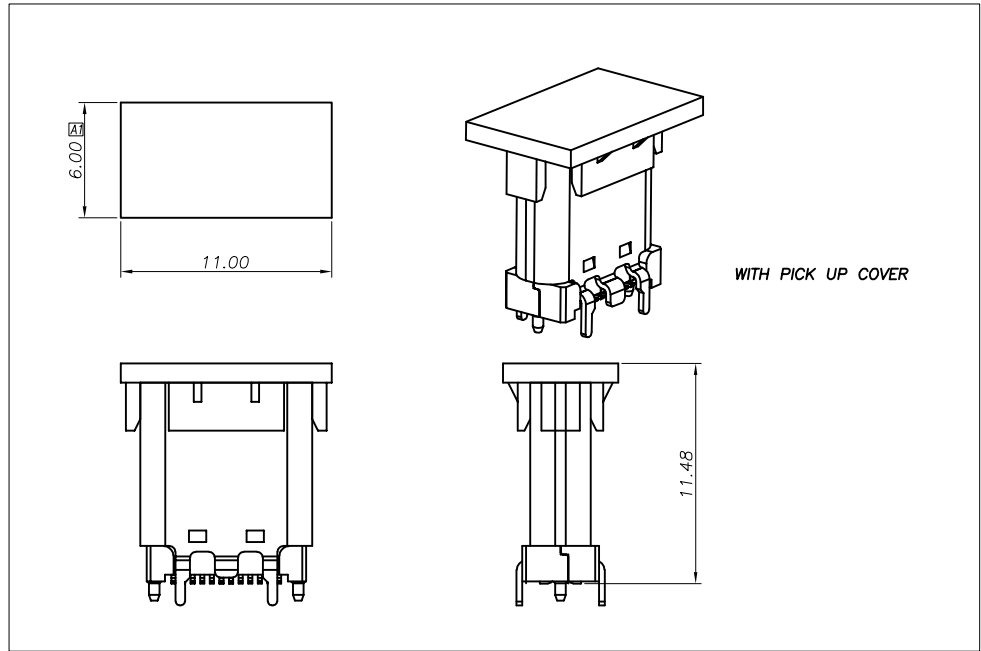

USB TYPE-C PIN ASSIGNMENTS

PIN NUMBER	SIGNAL NAME	PIN NUMBER	SIGNAL NAME
A1	GND	B12	GND
A2	SSTXp1	B11	SSRXp1
A3	SSTXn1	B10	SSRXn1
A4	Vbus	B9	Vbus
A5	CC1	B8	SBU2
A6	Dp1	B7	Dn2
A7	Dn1	B6	Dp2
A8	SBU1	B5	CC2
A9	Vbus	B4	Vbus
A10	SSRXn2	B3	SSTXn2
A11	SSRXp2	B2	SSTXp2
A12	GND	B1	GND

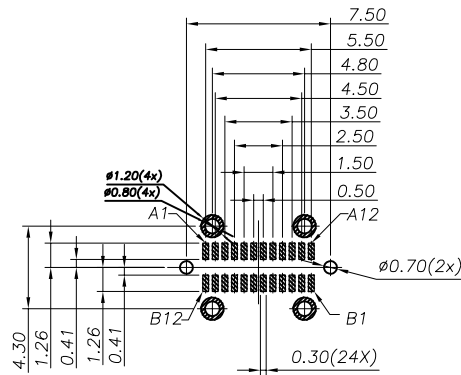

RECOMMENDED PCB LAYOUT(TOP VIEW)

DEFAULT TOLERANCE:±0.05

Bestcreate Technology Limited

TOLERANCES UNLESS OTHERWISE SPECIFIED:

.X	± 0.30	X'	± 10°
.XX	± 0.20	.XX'	± 8°
.XXX	± 0.10	.XXX'	± 5°

Website:www.bsc-elec.com

Email:bestcreate@bsc-elec.com

DESIGN:
I. L

DATE:

CHECKED:
C. W

DATE:

APPROVED:
C. W

DATE:

TITLE:

TYPE CF 24P VERTICAL(H=10.50) TAIL LENGTH:1.15MM

MATERILA:

PART NO:
U06-CFXX5X-088-V3

SIZE:
A4

FINSH:

DWG NO:
U06-CFXX5X-088-V3

2 OF 3

REV:
A

UNIT
mm

SCALE
1=1

QUALITY
SYMBOLS

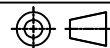

RoHS Compliant

REVISIONS			
REV.	DESCRIPTION	DATE	DESIGN

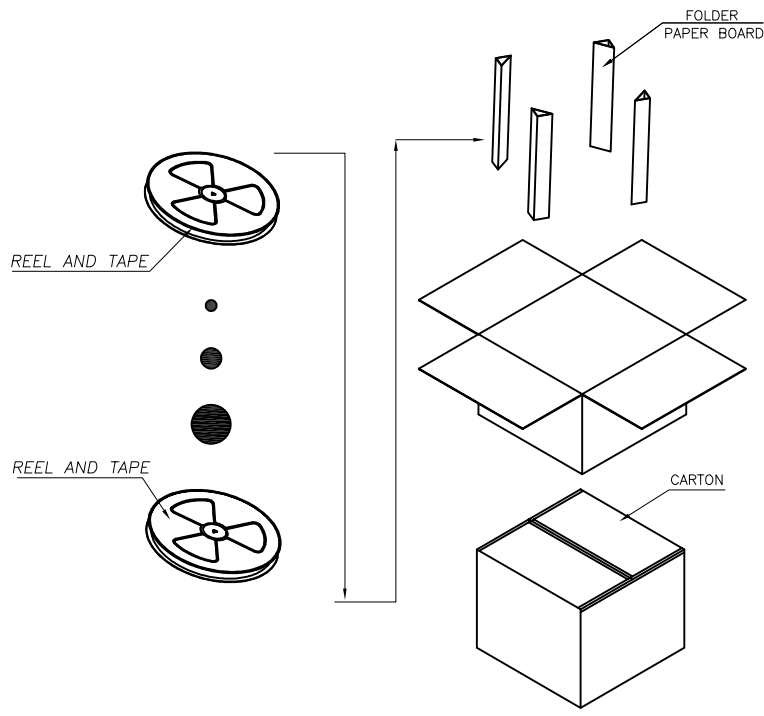
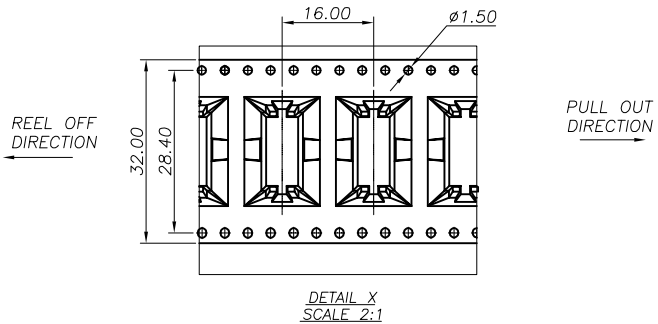
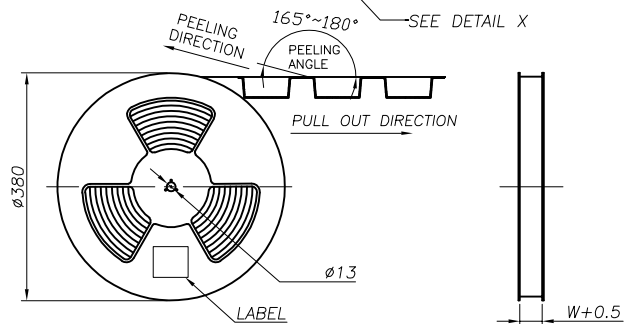
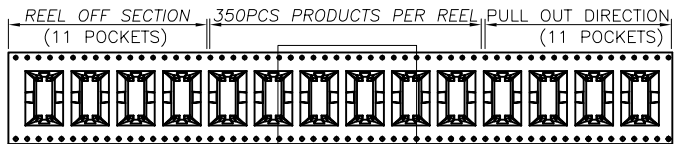

	REEL/TRAY	CARTON
CONNECTOR (PCS)	350	2800

Bestcreate Technology Limited

TOLERANCES UNLESS OTHERWISE SPECIFIED:

.X	± 0.30	X'	± 10'
.XX	± 0.20	.XX'	± 8'
.XXX	± 0.10	.XXX'	± 5'

Website: www.bsc-elec.com
 Email: bestcreate@bsc-elec.com

DESIGN: I. L DATE: _____
 CHECKED: C. W DATE: _____
 APPROVED: C. W DATE: _____

TITLE: TYPE CF 24P VERTICAL (H=10.50) TAIL LENGTH:1.15MM
 MATERILA: PART NO: U06-CFXX5X-088-V3 SIZE: A4
 FINSH: DWG NO: U06-CFXX5X-088-V3 3 OF 3

REV:	UNIT	SCALE	QUALITY SYMBOLS
A	mm	1=1	