

RoHS Compliant

REVISIONS			
REV.	DESCRIPTION	DATE	DESIGN

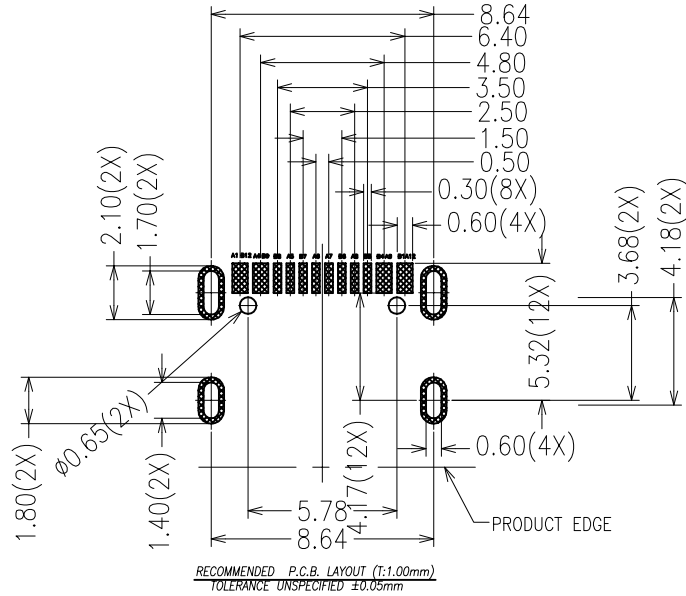
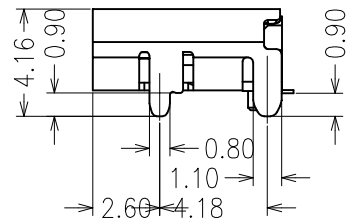
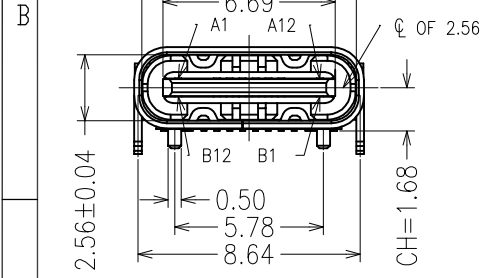
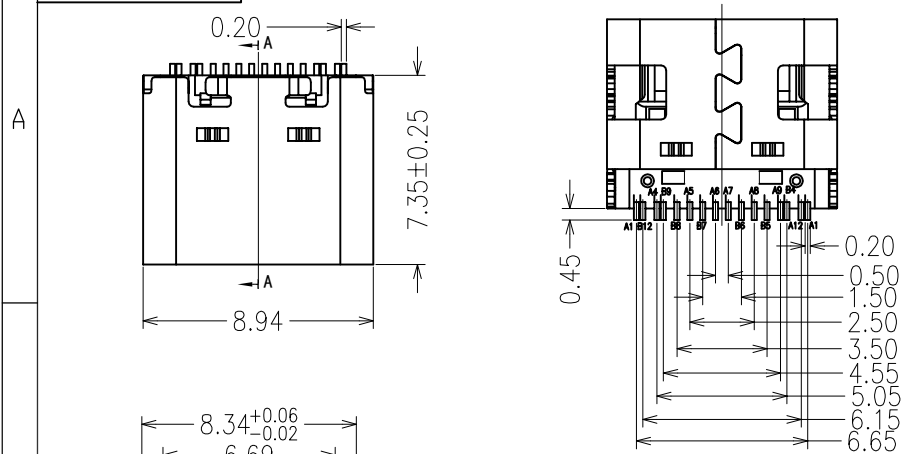

RECOMMENDED P.C.B. LAYOUT (T:1.00mm)  
TOLERANCE UNSPECIFIED ±0.05mm

- 规格说明: Specifications:  
电气特性: Electrical:
- 额定电流: Current Rating 5A/contact terminal
  - 额定电压: Voltage Rating 30V DC
  - 接触阻抗: Contact Resistance 40 milliohms MAX
  - 耐压: Dielectric Withstanding Voltage: 100 V AC AT Sea Level
  - 绝缘阻抗: Insulation Resistance: 100MEGA ohms MIN
- 物理性能: Mechanical:
- 插拔力: Connector Mates and Unmate Force Mmate Force: 5-20N Unmate Force: 8-20N, After 10000 Cycles 6-20N
  - 寿命测试: Life Test 10,000 Cycles
  - 端子保持力: Terminal Retention 0.5kgf (MIN)
- 原材料: Material:
- 塑胶: Housing: High Temperature Plastic, Ul 94V-0 LCP Black/Nature
  - 端子: Contact: Copper With High Conductivity
  - 外壳: Shell: Stainless Steel
  - 中夹片: Middle Clip: Stainless Steel
- 电镀: Finish:
- 端子: Contact: Plated 3u" Au On Mating Area: Gold Flash On Welding Area.
  - 外壳: Shell: Plated Nickel 100~200u"

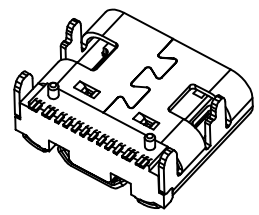
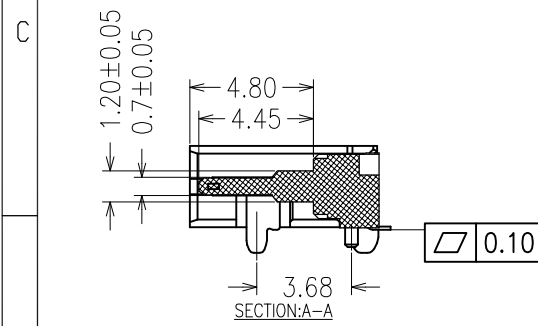

USB TYPE-C PIN ASSIGNMENTS

PIN NUMBER	SIGNAL NAME	PIN NUMBER	SIGNAL NAME
A1	GND	B12	GND
A4	V BUS	B9	V BUS
A5	CC1	B8	SBU2
A6	Dp1	B7	Dn2
A7	Dn1	B6	Dp2
A8	SBU1	B5	CC2
A9	V BUS	B4	V BUS
A12	GND	B1	GND

PART NO. INFORMATION

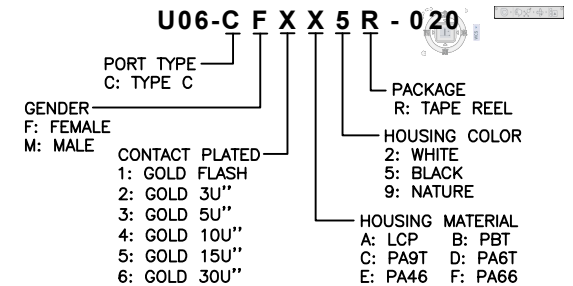

**Bestcreate Technology Limited**

TOLERANCES UNLESS OTHERWISE SPECIFIED:

X.	± 0.30	X.*	± 10*
.X	± 0.20	.X*	± 8*
.XX	± 0.10	.XX*	± 5*

Website: [www.bsc-elec.com](http://www.bsc-elec.com)  
E-mail: [bestcreate@bsc-elec.com](mailto:bestcreate@bsc-elec.com)

DESIGN:	I. L	DATE:	2017. 3. 1
CHECKED:	C. W	DATE:	2017. 3. 1
APPROVED:	C. W	DATE:	2017. 3. 1

TITLE: 16P USB C TYPE FEMALE		
MATERILA:	PART NO: U06-CFXX5R-020	SIZE: A4
FINSH:	DWG NO: U06-CFXX5R-020	SHEET: 1 OF 3

REV: A	UNIT	SCALE mm 1=1	QUALITY SYMBOL
--------	------	--------------------	----------------

RoHS Compliant

REVISIONS			
REV.	DESCRIPTION	DATE	DESIGN

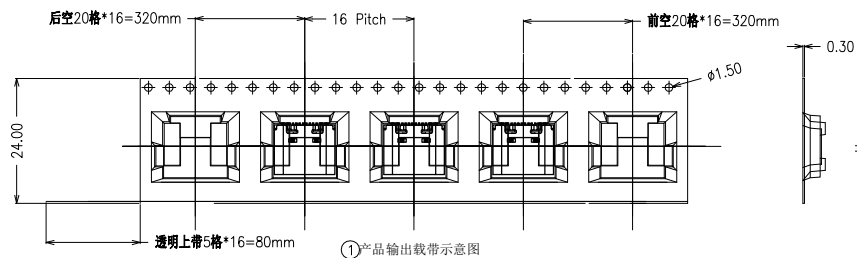

图一

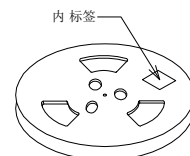

图二

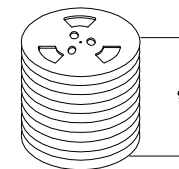

图三

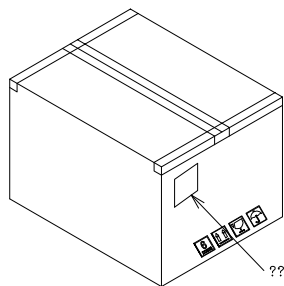

图六

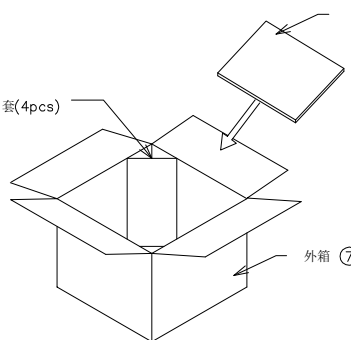

图五

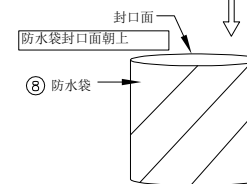

图四

TABLE A

NO.	DESCRIPTION	QUANTITY
①	USB TYPE C 16P	10 K
②	GP PET,W=21.3mm	16mm*10k
③	W=24mm P=16mm T=0.35mm(1/13.44m)	16mm*10k
④	330*24.0	10PCS
⑤	390*390*3mm	2PCS
⑥	320(90+140+90)*300mm	4PCS
⑦	330*330*305mm K=K	1PCS
⑧	600*600*0.15	1PCS

包装说明:

- 1.将检验好的成品;SMT朝下放入载带底部;每卷装1000PCS产品;具体如图一所示
- 2.将包装好的产品;每盘必需贴上内标签;具体如图二所示
- 3.将贴好内标签的产品每10盘叠一层装入防水袋中并加一包干燥剂;装好后将防水袋封好;具体如图三图四所示
- 4.先将1pcs平卡放入纸箱底部;然后将装好产品的防水袋装入纸箱中;防水袋热封朝上;封口面朝上;并将4PCS三角套分别装入4个角;如图五所示
- 5.装好后将1pcs平卡放入纸箱最上面并封好纸箱及贴好相关标签;具体如图六所示;(产品包装的标签,如客户有要求,请按客户要求包装出货)
- 6.载带前面和后面各留20PCS空格
- 7.COVER与CARRY剥离力:50-125g,速度:300mm/分钟左右,剥离角度:165°-180°

**Bestcreate Technology Limited**

TOLERANCES UNLESS OTHERWISE SPECIFIED:

X.	± 0.30	X.*	± 10°
.X	± 0.20	.X*	± 8°
.XX	± 0.10	.XX*	± 5°

DESIGN: I. L DATE: 2017. 3. 1

CHECKED: C. W DATE: 2017. 3. 1

APPROVED: C. W DATE: 2017. 3. 1

TITLE: 16P USB C TYPE FEMALE

MATERILA: PART NO: U06-CFXX5R-020 SIZE: A4

FINSH: DWG NO: U06-CFXX5R-020 SHEET: 1 OF 3

REV: A UNIT SCALE mm 1=1 QUALITY SYMBOL

Website: www.bsc-elec.com E-mail: bestcreate@bsc-elec.com