

RoHS Compliant

REVISIONS			
REV.	DESCRIPTION	DATE	DESIGN

Item No	Shell No	Shell Color	Plating
1.02.07.018-1	5.10.127-1	BLACK	NICKEL
1.02.07.019-3	5.10.128-3	SLIVER	NICKEL
1.02.07.020-9	5.10.129-9	GOLD	NICKEL
1.02.07.021-10	5.10.130-10	GRAY	NICKEL
1.02.07.022-14	5.10.131-14	ROSE GOLD	NICKEL

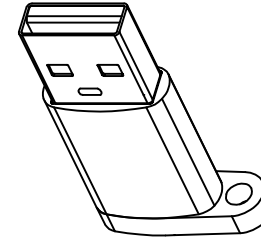
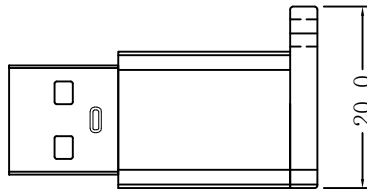

CN1

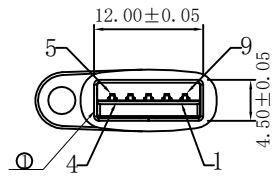

CN2

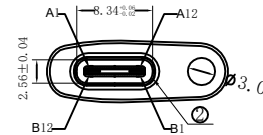
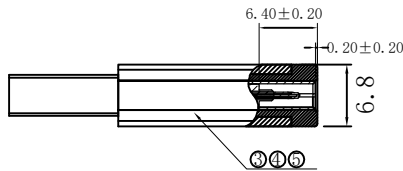

CONTACT

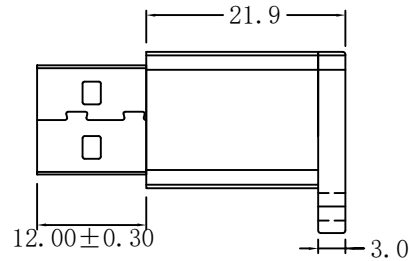
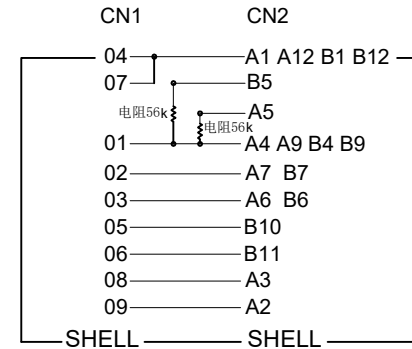

5	Outer Mold	Aluminium Alloy SHELL	5.10.127-131	2.3G
4	Internal mold	PVC SIZING MATERIAL 45P BLACK	5.09.02-1	1.0G
3	In-connection	PCB T=0.8MM 2*Resistor 56K	5.12.239	1PCS
2	Connector	USB TYPE CF SHELL NICKEL PLATED PIN G/F	5.03.60	1PCS
1	Connector	USB 3.0 AM SHELL NICKEL PLATED PIN G/F BLUE	5.03.26	1PCS
NO	NAME	MATERIAL	NO	QTY

NOTES:

- 100% open short test condition;
- Conductor Resistance $\leq 5\Omega$, insulation resistance $\geq 10M\Omega$.
High voltage test, DC 300V/10mS.
- Support Power Charging、Data Transfer.
- PCB Board Connection.

Bestcreate Technology Limited

TOLERANCES UNLESS OTHERWISE SPECIFIED:

X.	± 0.50	X.*	± 5°
.X	± 0.30	.X*	± 2°
.XX	± 0.10	.XX*	± 1°

DESIGN: I.L DATE: 2017.3.1

CHECKED: C.W DATE: 2017.3.1

APPROVED: C.W DATE: 2017.3.1

TITLE: USB3.0 AM TO TYPE CF 180°

MATERILA: FINSH: PART NO: AD30AMCF-001 SIZE: A4

DWG NO: AD30AMCF-001

REV: A UNIT: mm SCALE: 1=1 QUALITY SYMBOLS:

Website: www.bsc-elec.com
Email: bestcreate@bsc-elec.com