

RoHS Compliant

REVISIONS			
REV.	DESCRIPTION	DATE	DESIGN

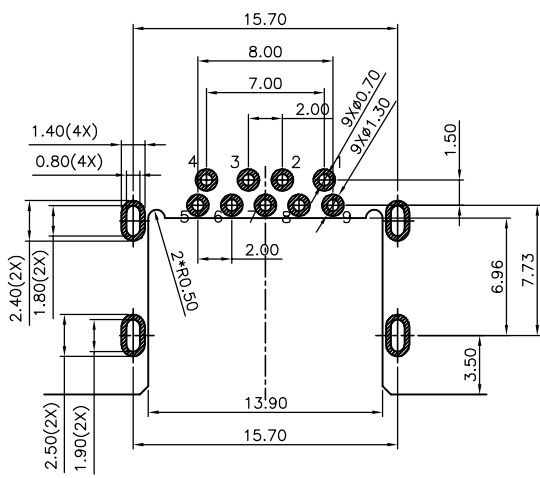
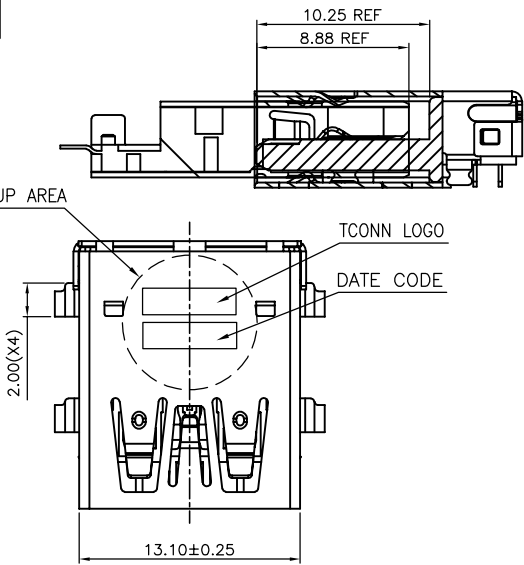

TOLERANCE: ±0.05, THICKNESS: 1.2mm
RECOMMENDED PCB LAYOUT
 (TOP VIEW)

- NOTE:
- MATERIAL:
 - INSULATOR:LCP E130I+30% G/F UL 94 V-0 COLOR;BLUE
 - CONTACT:C5191(T=0.20mm)
 - SHELL:SUS304(T=0.30mm)
 - ELECTRICAL CHARACTERISTICS:
 - Current Rating:1.8
 - Insulation Resistance:100MΩ Min
 - Contact Resistance:30mΩ Max
 - Dielectric Withstanding Voltage:500V AC
 - OPERATING TEMPERATURE:-40°C ~ 85°C
 - MECHANICAL CHARACTERISTICS:
 - MATING FORCE:35 N Max
 - UNMATED FORCE:10 N Min INITIAL; 8 N Min AFTER TEST
 - DURABILITY:5,000 CYCLES
 - PLATING SPECIFICATION:
 - CONTACTS:Ni 50u" MIN. UNDER PLATED,GOLD FLASH PLATED ON THE MATING AREA OF CONTACT.
MATTE Sn 100u" MIN. PLATED ON THE SOLDER TALL.
 - FRONT SHELL:Ni 50u"MIN. UNDER PLATED OVER ALL.
 - Salt Spray 48H
 - ROSH2+HF

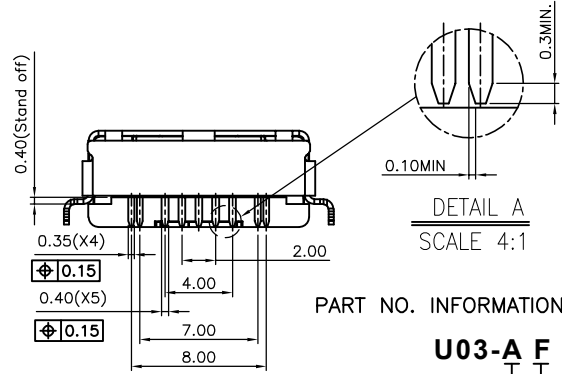
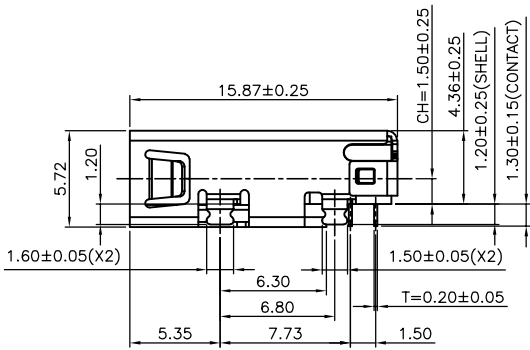
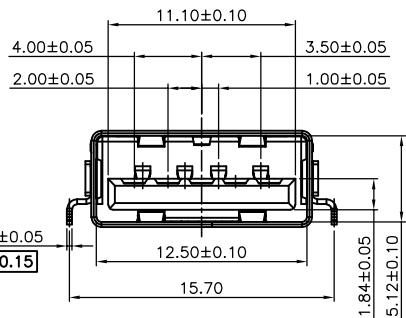

PART NO. INFORMATION

U03-A F X A X X -5013

PORT TYPE
A: TYPE A

GENDER
F: FEMALE
M: MALE

CONTACT PLATED
1: GOLD FLASH
2: GOLD 3U"
3: GOLD 5U"
4: GOLD 10U"
5: GOLD 15U"
6: GOLD 30U"

PACKAGE
T: TRAY R:TAPE REEL

HOUSING COLOR
2: WHITE
5: BLACK
9: BLUE

HOUSING MATERIAL
A: LCP B: PBT
C: PA9T D: PA6T
E: PA46 F: PA66

Pin #	SIGNAL NAME
1	VBUS
2	D-
3	D+
4	GND
5	StdA_SSRX-
6	StdA_SSRX+
7	GND_DRAIN
8	StdA_SSTX-
9	StdA_SSTX+
Shell	Shield

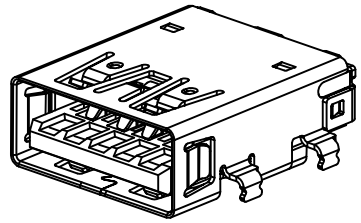

Bestcreate Technology Limited			TOLERANCES UNLESS OTHERWISE SPECIFIED:		DESIGN: I.L	DATE: 2017.3.1	TITLE: USB 3.0 AF 板下沉板CH=1.5mm L=15.87mm DIP YTPTE		
			X. ± 0.30	X.* ± 3*	CHECKED: C.W	DATE: 2017.3.1	MATERILA:	PART NO: U03-AFXAXX-5013	SIZE: A4
REV: A	UNIT mm	SCALE 1=1	QUALITY SYMBOLS	Website: www.bsc-elec.com	APPROVED: C.W	DATE: 2017.3.1	FINSH:	DWG NO: U03-AFXAXX-5013	SHEET: 1 OF 2
				E-mail: bestcreate@bsc-elec.com					

RoHS Compliant

REVISIONS			
REV.	DESCRIPTION	DATE	DESIGN

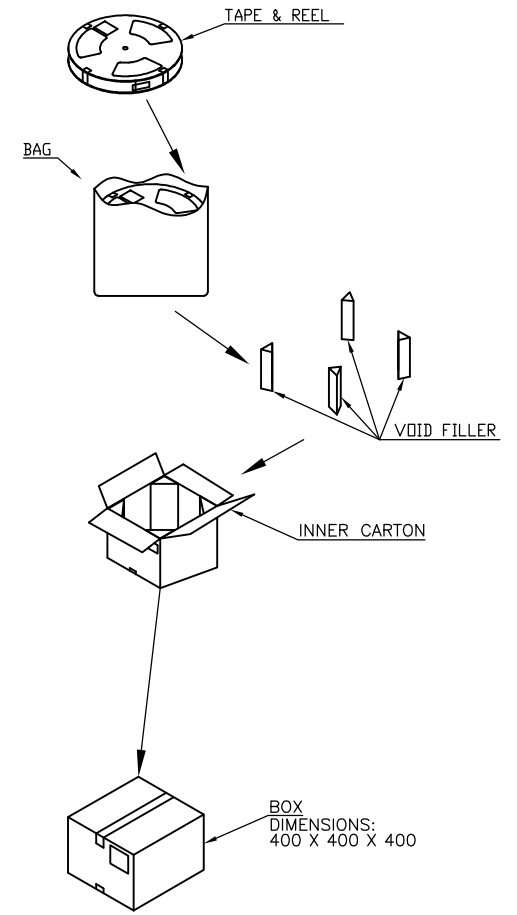
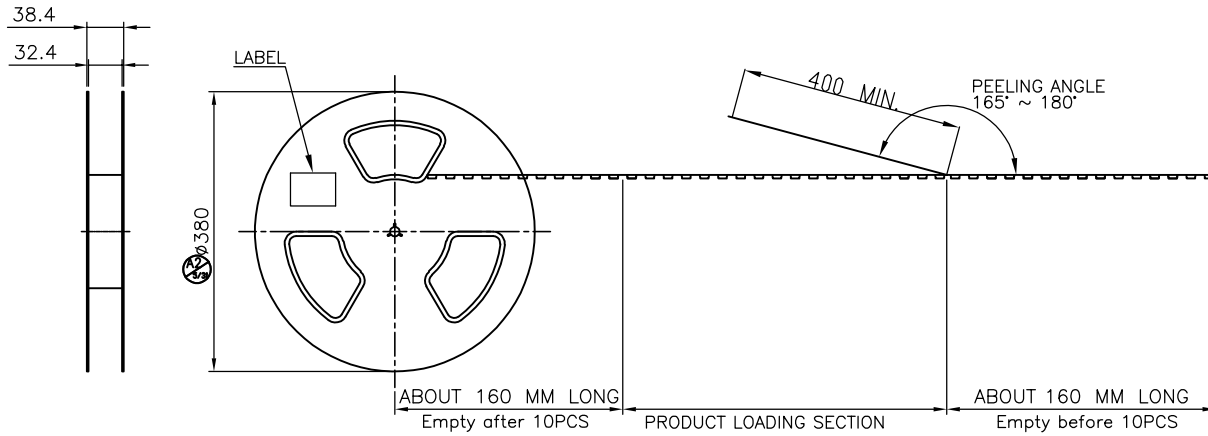

USER DIRECTION OF UNREELING →

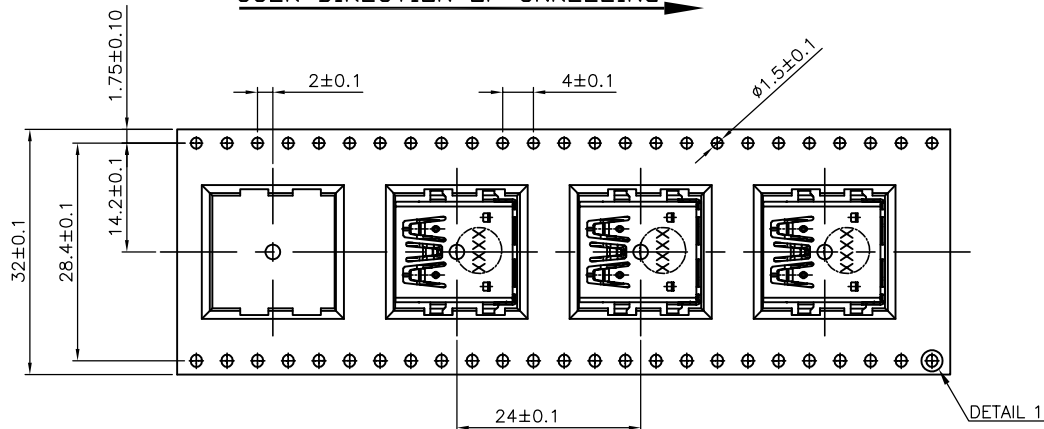

FEED DIRECTION →

(出料方向)

NOTE:

- MATERIAL:
 BOX: FIBREBOARD, CORRUGATED, DOUBLE WALL
 TAPE: POLYSTYRENES, HEAT-RESISTANT TEMPERATURE: 120°C, Transparent COLOR.
 REEL: POLYSTYRENES, HEAT-RESISTANT TEMPERATURE: 70°C, BLUE COLOR.
 BAG: POLYETHYLENE, HEAT-RESISTANT TEMPERATURE: 100°C.
- PEELING STRENGTH: 0.1 ~ 1.3 N (10 ~ 130 GRAMS)
- PEELING SPEED: 300 mm/min.
- EACH BAG SHALL BE INCLUDED DESICCANT.

600	10	6000 PCS	-- KG	-- KG
PCS/ REEL	REELS/ CARTON	QUANTITY	GROSS WEIGHT	NET WEIGHT

Bestcreate Technology Limited

TOLERANCES UNLESS OTHERWISE SPECIFIED:

X.	± 0.30	X.*	± 3*
.X	± 0.20	.X*	± 2*
.XX	± 0.15	.XX*	± 1*

Website: www.bsc-elec.com
 E-mail: bestcreate@bsc-elec.com

DESIGN: I.L
 DATE: 2017.3.1

CHECKED: C.W
 DATE: 2017.3.1

APPROVED: C.W
 DATE: 2017.3.1

TITLE: USB 3.0 AF 板下沉板CH=1.5mm
 L=15.87mm DIP YTPTE

MATERILA: PART NO: U03-AFXAXX-5013 SIZE: A4

FINSH: DWG NO: U03-AFXAXX-5013 SHEET: 2 OF 2

REV: A	UNIT mm	SCALE 1=1	QUALITY SYMBOLS
--------	---------	-----------	-----------------