

RoHS Compliant

REVISIONS			
REV.	DESCRIPTION	DATE	DESIGN

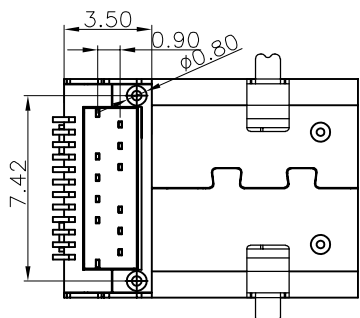
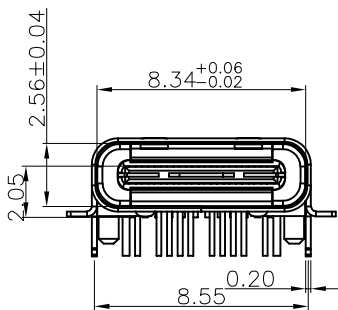
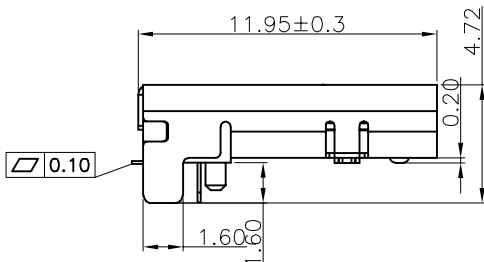
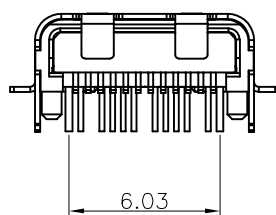
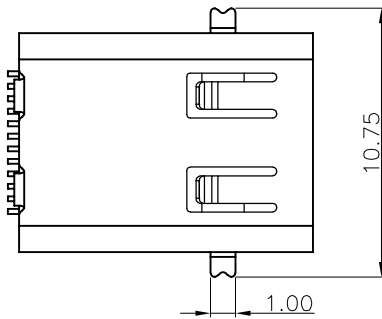
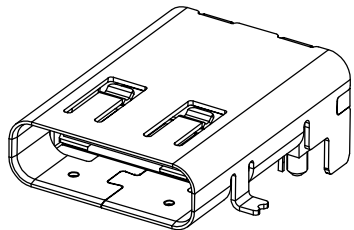

- 1.MATERIAL:
MOLDING: LCP UL94 V-0
CONTACT:COPPER ALLOY.
PLATED GOLD ON CONTACT AREA,
G/F GOLD ON SOLDER AREA,
50u" NICKEL PLATING OVER ALL.
- SHELL: SUS304-H,T=0.30±0.03mm
50u" NICKEL PLATING OVER ALL.
EMI SHILD:SUS304-H,T=0.12±0.03mm
LATCH:SUS301-H,T=0.15±0.03mm
- 2.MECHANICAL:
INSERTION: 5~20N.
EXTRACTION: 8~20N.
DURABILITY: 10000 CYCLES
- 3.ELECTRICAL:
CURRENT: 5A MIN FOR VBUS;
0.25A MIN FOR OTHER.
VOLTAGE: 5VAC MAX
WITHSTANDING VOLTAGE: 100V AC.
CONTACT RESISTANCE: 40mΩ MAX.
INSULATION RESISTANCE: 100MΩ MIN.
- 4.ENVIRONMENTAL
TEMPERATURE RANGE: -30°C TO +80°C

PART NO. INFORMATION

U06-C F X X 5 R-003

- PORT TYPE
C: TYPE C
- GENDER
F: FEMALE
M: MALE
- CONTACT PLATED
1: GOLD FLASH
2: GOLD 3U"
3: GOLD 5U"
4: GOLD 10U"
5: GOLD 15U"
6: GOLD 30U"
- PACKAGE
R: TAPE REEL
- HOUSING COLOR
2: WHITE
5: BLACK
9: NATURE
- HOUSING MATERIAL
A: LCP B: PBT
C: PA9T D: PA6T
E: PA46 F: PA66

Bestcreate Technology Limited

TOLERANCES UNLESS OTHERWISE SPECIFIED:

X.	± 0.30	X.'	± 10'
.X	± 0.20	.X'	± 8'
.XX	± 0.10	.XX'	± 5'

Website: www.bsc-elec.com
E-mail: bestcreate@bsc-elec.com

DESIGN: I.L	DATE: 2017/3/1
CHECKED: C.W	DATE: 2017/3/1
APPROVED: C.W	DATE: 2017/3/1

TITLE: USB 3.1 C TYPE DIP+SMT母座 加长型 12.0L		
MATERILA:	PART NO: U06-CFXX5R-003	SIZE: A4
FINSH:	DWG NO: U06-CFXX5R-003	SHEET: 1 OF 3

REV: A	UNIT mm	SCALE 1=1	QUALITY SYMBOLS
-----------	------------	--------------	-----------------

REVISIONS			
REV.	DESCRIPTION	DATE	DESIGN

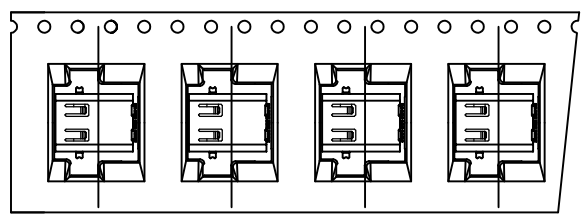

① 产品入载带示意图

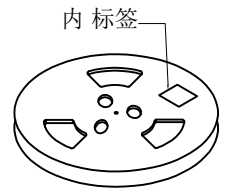

② 卷盘贴标签示意图

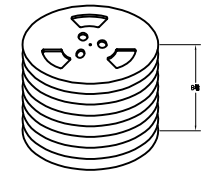

③ 7盘产品叠层示意图

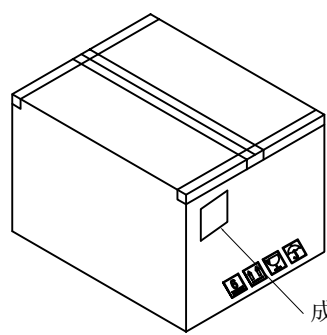

⑥ 外箱封箱示意图

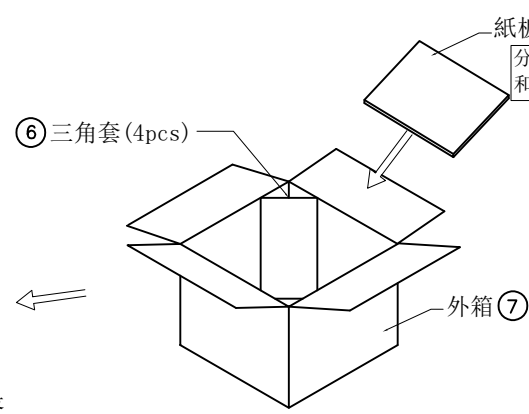

⑤ 产品入外箱示意图

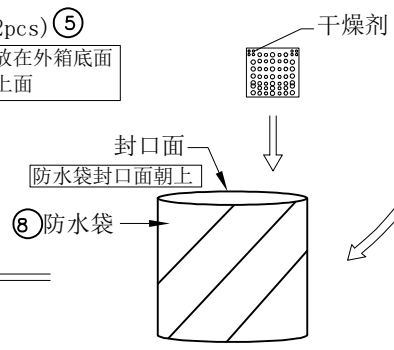

④ 7盘产品入防水袋示意图

包装说明:

1. 将检验好的成品;SMT朝下放入载带底部;每卷装1000PCS产品;具体如图一所示
2. 将包装好的产品;每盘必需贴上内标签;具体如图二所示
3. 将贴好内标签的产品每8盘叠一层装入防水袋中并加一包干燥剂;装好后将防水袋封好;具体如图三图四所示
4. 先将1pcs平卡放入纸箱底部;然后将装好产品的防水袋装入纸箱中;防水袋热熔封口,封口面需朝上;并将4PCS三角套分别装入4个角;如图五所示
5. 装好后将1pcs平卡放入纸箱最上面并封好纸箱及贴好相关标签;具体如图六所示;
(产品包装的标签,如客户有要求,请按客户要求包装出货)
6. 载带前面留30PCS空格,后面留20PCS空格
7. COVER与CARRY剥离力:50-125g,速度:300mm/分钟左右,剥离角度:165° -180°

Bestcreate Technology Limited

TOLERANCES UNLESS OTHERWISE SPECIFIED:			
X.	± 0.30	X.'	± 10°
.X	± 0.20	.X'	± 8°
.XX	± 0.10	.XX'	± 5°
Website: www.bsc-elec.com			
E-mail: bestcreate@bsc-elec.com			

DESIGN:	I.L	DATE:	2017/3/1
CHECKED:	C.W	DATE:	2017/3/1
APPROVED:	C.W	DATE:	2017/3/1

TITLE: USB 3.1 C TYPE DIP+SMT母座 加长型 12.0L		
MATERILA:	PART NO:	SIZE:
	U06-CFXX5R-003	A4
FINSH:	DWG NO:	SHEET:
	U06-CFXX5R-003	3 OF 3

REV:	UNIT	SCALE	QUALITY SYMBOLS
A	mm	1=1	