

RoHS Compliant

REVISIONS			
REV.	DESCRIPTION	DATE	DESIGN

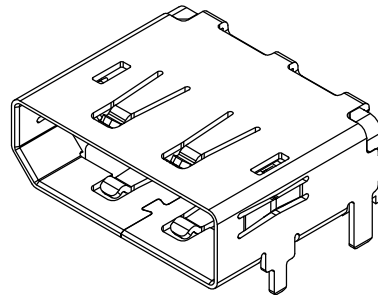

NOTE:
 1.MATERIAL:
 1.1 HOUSING: LCP, UL 94V-0
 COLOR: BLACK.
 1.2 CONTACT: C2680, T=0.20mm.
 1.3 SHIELD: C2680, T=0.40mm.
 1.4 COVER: LCP,UL 94V-0
 2.FINISH:
 2.1 CONTACT: GOLD(1U") PLATING IN CONTACT AREA,
 80u"MIN Tin PLATED IN SOLDER AREA,
 50u" MIN. NICKEL UNDERPLATED OVERALL.
 2.2 SHIELD: 50u" MIN. NICKEL UNDERPLATED OVERALL.
 3.MECHANICAL CHARACTERISTICS
 3.1 RATING CURRENT: 0.5A
 3.2 RATING VOLTAGE: 40V
 3.3 CONTACT RESISTANCE: 40 mΩ MAX
 3.4 INSULATION RESISTANCE:
 a, UNMATED: 100MΩ MIN AT 500 VDC
 b, MATED: 10M OHMS MIN AT 150 VDC
 3.5 DIELECTRIC WITHSTANDING VOLTAGE: 500V AC/1MINUTE
 3.6 DURABILITY: 10000 CYCLES.
 3.7 OPERATING TEMPERATURE: -20°C--+85°C
 3.8 STORAGE TEMPERATURE: -20°C--+65°C
 4. NOTES:
 4.1 ALL COMPONENTS ARE RoHS COMPLIANT.
 4.2 RESISTANCE TO SOLDERING HEAT: 265°C FOR 10 SECONDS.

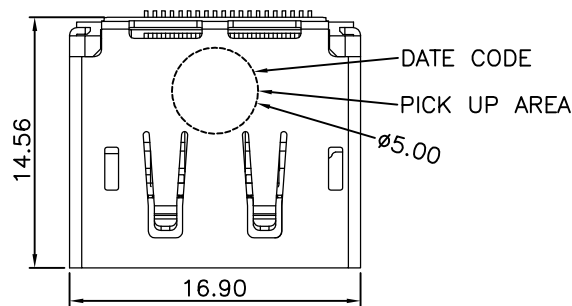
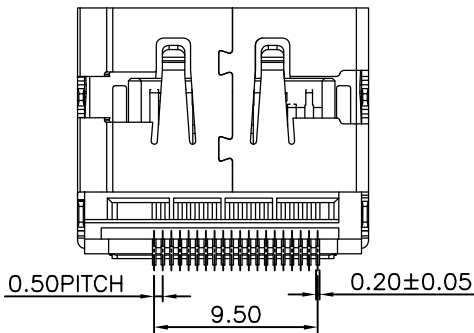
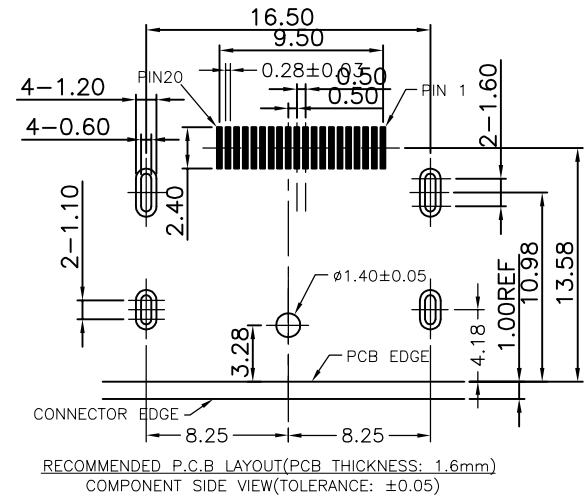
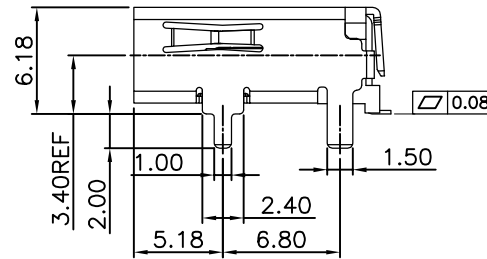
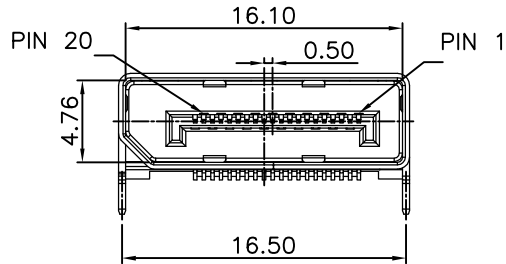

PART NO. INFORMATION

DP09- F X X 5 R - 003

GENDER:
 F: FEMALE
 M: MALE

CONTACT PLATED:
 1: GOLD FLASH
 2: GOLD 3U"
 3: GOLD 5U"
 4: GOLD 10U"
 5: GOLD 15U"
 6: GOLD 30U"

PACKAGE:
 R: TAPE REEL T:TRAY

HOUSING COLOR:
 2: WHITE
 5: BLACK
 9: NATURE

HOUSING MATERIAL:
 A: LCP B: PBT
 C: PA9T D: PA6T
 E: PA46 F: PA66

Bestcreate Technology Limited

TOLERANCES UNLESS OTHERWISE SPECIFIED:

X.	± 0.50	X.*	± 5°
.X	± 0.38	.X*	± 2°
.XX	± 0.25	.XX*	± 1°

DESIGN: I. L
 DATE: 2017. 3. 1

CHECKED: C. W
 DATE: 2017. 3. 1

APPROVED: C. W
 DATE: 2017. 3. 1

TITLE: TOP MOUNT DISPLAY PORT FEMALE CONNECTOR
 20P SMT A TYPE

MATERIAL: PART NO: DP09-FXX5R-003
 SIZE: A4

FINSH: DWG NO: DP09-FXX5R-003

REV: A	UNIT mm	SCALE 1=1	QUALITY SYMBOLS
--------	---------	-----------	-----------------