

RoHS Compliant

REVISIONS			
REV.	DESCRIPTION	DATE	DESIGN

NOTE:

- MATERIAL:
 - INSULATOR:PA9T, UL 94 V-0;COLOR BLACK
 - 4PIN CONTACT:C5191(T=0.20mm)
 - 5PIN CONTACT:C2680(T=0.20mm)
 - SHELL:SUS304(T=0.20mm)
- ELECTRICAL CHARACTERISTICS:
 - Current Rating:1.8
 - Insulation Resistance:100MΩ Min
 - Contact Resistance:30mΩ Max
 - Dielectric Withstanding Voltage:500V AC
 - OPERATING TEMPERATURE:-40°C ~ 85°C
- MECHANICAL CHARACTERISTICS:
 - MATING FORCE:2.5kgf Max
 - UNMATED FORCE:0.8kgf Min
 - DURABILITY:5,000 CYCLES
- PLATING SPECIFICATION:
 - CONTACTS:Ni 50u" MIN. UNDER PLATED,GOLD FLASH PLATED ON THE MATING AREA OF CONTACT.
MATTE Sn 100u" MIN. PLATED ON THE SOLDER TALL.
 - FRONT SHELL:Ni 50u"MIN TEST POINT
 - Salt Spray 48H

PART NO. INFORMATION

U03-A F X A X X -5021

- PORT TYPE
A: TYPE A
- PACKAGE
T: TRAY R:TAPE REEL
- HOUSING COLOR
2: WHITE
5: BLACK
9: BLUE
- CONTACT PLATED
1: GOLD FLASH
2: GOLD 3U"
3: GOLD 5U"
4: GOLD 10U"
5: GOLD 15U"
6: GOLD 30U"
- HOUSING MATERIAL
A: LCP B: PBT
C: PA9T D: PA6T
E: PA46 F: PA66
- GENDER
F: FEMALE
M: MALE

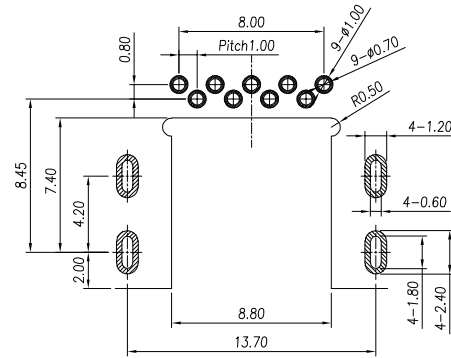
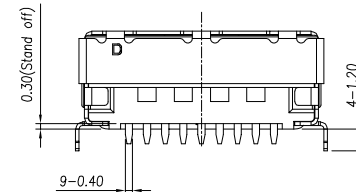
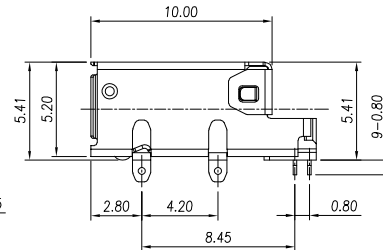
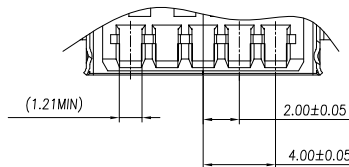
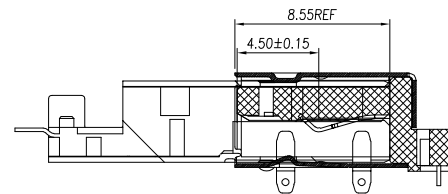
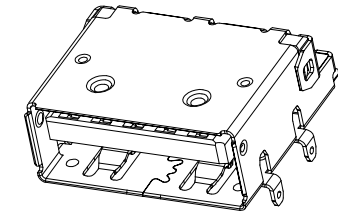

TOLERANCE: ±0.05,
RECOMMENDED PCB LAYOUT
(TOP VIEW)

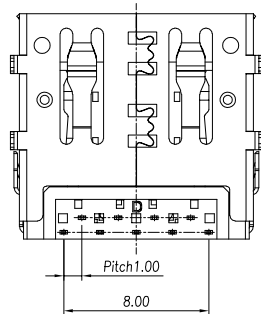
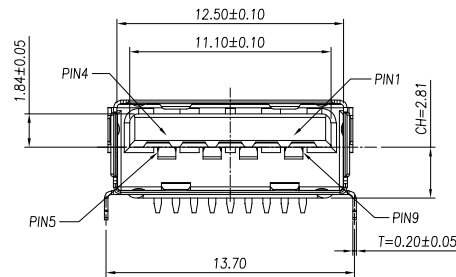
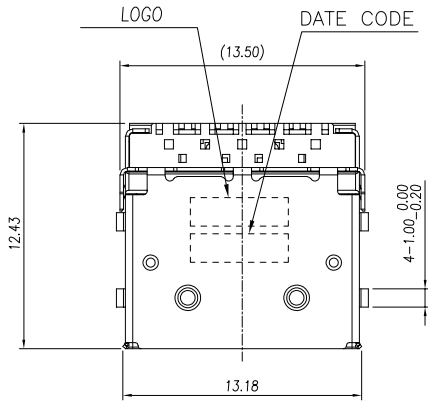

Bestcreate Technology Limited

TOLERANCES UNLESS OTHERWISE SPECIFIED:

X.	± 0.30	X.*	± 3*
.X	± 0.20	.X*	± 2*
.XX	± 0.15	.XX*	± 1*

Website: www.bsc-elec.com

E-mail: bestcreate@bsc-elec.com

DESIGN: **I.L** DATE: **2017.3.1**

CHECKED: **C.W** DATE: **2017.3.1**

APPROVED: **C.W** DATE: **2017.3.1**

TITLE: **USB 3.1 TYPE A 9P,H=5.20MM CH=2.81MM
L=12.43MM REC, STD, DIP TYPE**

MATERIAL:	PART NO:	SIZE:
	U03-AFXAXX-5021	A4
FINSH:	DWG NO:	SHEET:
	U03-AFXAXX-5021	1 OF 2

REV:	UNIT	SCALE	QUALITY SYMBOLS
A	mm	1=1	