

RoHS Compliant

| REVISIONS | | | |
|-----------|-------------|------|--------|
| REV. | DESCRIPTION | DATE | DESIGN |
| | | | |

特性:Specifications;
 电器:Electyical:
 接触阻抗:Contact Resistance
 30 millionms MAX
 耐电压:Dielectyic Withstanding Voltage:
 100v AC AT Sea Level
 绝缘阻抗:Insulation Resistance:
 100 MEGA ohms Min

机构:Machanical:
 插入力:Mating Force;
 3.57 KG MAX 最大3.57Kg
 拔出力:Unmating Force;
 0.714KG MIN. 最少0.714KG

材料:Material:
 塑胶:Housing:LCP Thermoplastics
 UL 94V-0 LCP耐高温塑胶
 端子>Contact:C2680H
 铁壳:Shell:SPCC铁壳
 电镀:Finish:
 端子>Contact:Plated Gold in Mating Area;
 Tin/On Solder Tails 接触点镀金;脚镀锡
 铁壳:Shell:
 ickel Plating镀镍

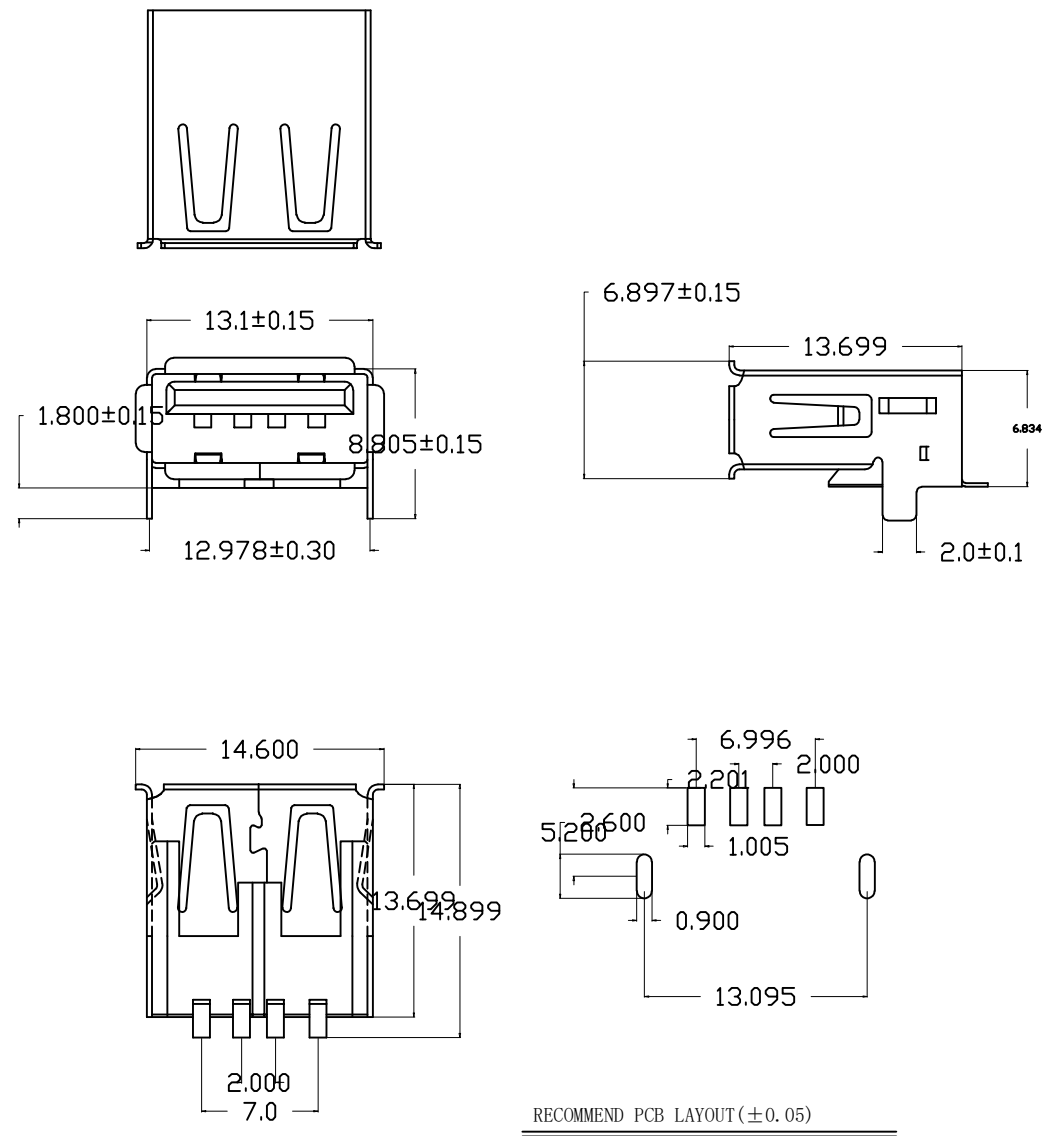

PART NO. INFORMATION
U02-5AFXXT-007

PIN NUMBER
 5: 5PIN
 PORT TYPE
 A: TYPE A
 GENDER
 F: FEMALE
 M: MALE
 CONTACT PLATED
 1: GOLD FLASH 2: GOLD 3U"
 3: GOLD 5U" 4: GOLD 10U"
 5: GOLD 15U" 6: GOLD 30U"

PACKAGE
 T: TRAY R: TAPE&REEL
 HOUSING COLOR
 1: ORANGE 2: BLUE
 5: BLACK 9: GREEN
 HOUSING MATERIAL
 A: LCP B: PBT
 C: PA9T D: PA6T
 E: PA46 F: PA66

Bestcreate Technology Limited

| TOLERANCES UNLESS OTHERWISE SPECIFIED: | | | | | |
|--|---|------|------|---|----|
| .X | ± | 0.30 | X' | ± | 5' |
| .XX | ± | 0.20 | .X' | ± | 2' |
| .XXX | ± | 0.10 | .XX' | ± | 1' |
| Website:www.bsc-elec.com | | | | | |
| Email:bestcreate@bsc-elec.com | | | | | |

| | |
|-----------|----------|
| DESIGN: | DATE: |
| I. L | 2017.3.1 |
| CHECKED: | DATE: |
| C. W | 2017.3.1 |
| APPROVED: | DATE: |
| C. W | 2017.3.1 |

| | | |
|---|----------------|-------|
| TITLE: | | |
| USB 2.0 A FEMALE CONNECTOR SMT TYPE 90° | | |
| MATERILA: | PART NO: | SIZE: |
| | U02-5AFXXT-007 | A4 |
| FINSH: | DRG NO: | |
| | U02-5AFXXT-007 | |

| | | | |
|------|------|-------|-----------------|
| REV: | UNIT | SCALE | QUALITY SYMBOLS |
| A | mm | 1=1 | |