

RoHS Compliant

REVISIONS			
REV.	DESCRIPTION	DATE	DESIGN

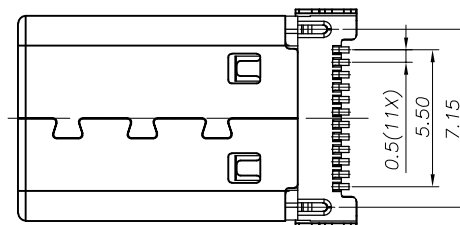
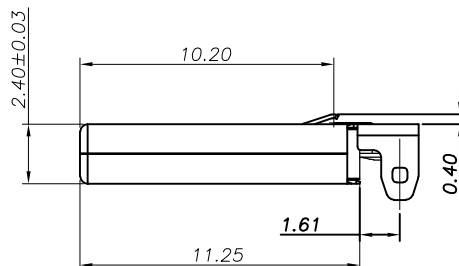
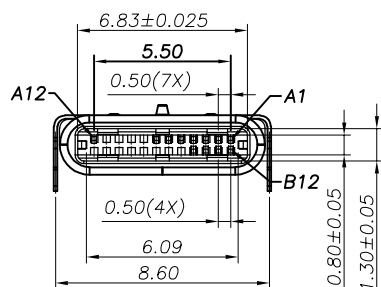
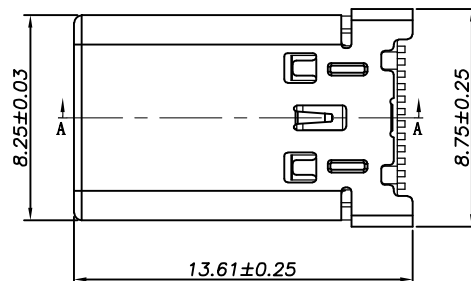
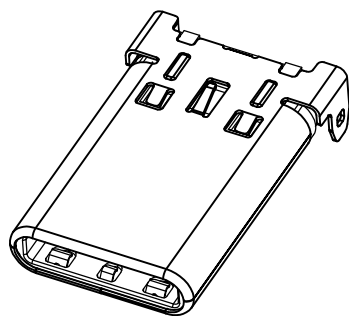

- NOTE:
- MATERIAL SPECIFICATION:
 - HOUSING: HIGH TEMPERATURE RESISTANT PLASTIC, UL94 V-0.
 - CONTACTS: COPPER ALLOY
 - MID PLATE: STAINLESS STEEL
 - FRONT SHELL: STAINLESS STEEL
 - EMI PLATE: STAINLESS STEEL
 - PLATING SPECIFICATION:
 - CONTACTS:
 - Ni 50u" MIN. UNDER PLATED OVER ALL.
 - Au PLATED ON THE FUNCTIONAL AREA OF CONTACT. (GOLD PLATING THICKNESS FOLLOW THE P/N)
 - PLATING SPECIFICATIONS OF THE SOLDER AREA FOLLOW THE P/N
 - FRONT SHELL:
 - Ni 30u" MIN. UNDER PLATED OVER ALL.
 - MID PLATE:
 - Ni 50u" MIN. UNDER PLATED OVER ALL.
 - EMI PLATE:
 - CLEAR ONLY
 - MECHANICAL PERFORMANCE,
 - INSERTION FORCE: 0.5~2.0kgf.
 - REMOVAL FORCE: 0.8kgf~2.0kgf.
 - DURABILITY: 10000 CYCLES.
 - ELECTRICAL PERFORMANCE,
 - CURRENT RATING: 3.0A
VOLTAGE RATING: 5.0V
 - LLCR:
 - VBUS & GND PINS AND OTHER PINS: 40mΩ/PIN MAX.
 - SHIELD: 50mΩ/MAX.
 - LLCR MAX. CHANGE OF ALL PINS: 10mΩ.
 - INSULATION RESISTANCE: 100MΩ MIN
 - DIELECTRIC WITHSTAND VOLTAGE, AC 100V FOR 1 MINUTE.
 - ENVIRONMENTAL PERFORMANCE:
 - OPERATING TEMPERATURE: -25°C~+85°C.
 - IR REFLOW:
 - THE PEAK TEMPERATURE ON THE BOARD SHALL BE MAINTAINED FOR 10 SECONDS AT 260°C.

PART NO. INFORMATION

U06-C M X X 5 R - 033

- PORT TYPE
C: TYPE C
- GENDER
F: FEMALE
M: MALE
- CONTACT PLATED
1: GOLD FLASH
2: GOLD 3U"
3: GOLD 5U"
4: GOLD 10U"
5: GOLD 15U"
6: GOLD 30U"
- PACKAGE
R: TAPE&REEL
- HOUSING COLOR
2: WHITE
5: BLACK
- HOUSING MATERIAL
A: LCP B: PBT
C: PA9T D: PA6T
E: PA46 F: PA66

TABLE 1

ITEM	P/N	HOUSING COLOR	CONTACTS	
			FUNCTIONAL AREA	SOLDER AREA
1	U06-CM1A5R-034	BLACK	Au:1u"	Sn 80u"

Bestcreate Technology Limited

TOLERANCES UNLESS OTHERWISE SPECIFIED:

.X	± 0.30	X.'	± 3'
.XX	± 0.20	.X'	± 2'
.XXX	± 0.10	.XX'	± 1'

Website: www.bsc-elec.com
Email: bestcreate@bsc-elec.com

DESIGN: I. L
DATE:
CHECKED: C. W
DATE:
APPROVED: C. W
DATE:

TITLE:
12P USB TYPE C MALE SMT CONNECTOR DIP SHELL
MATERILA:
PART NO: U06-CM1A5R-034
SIZE: A4
FINSH:
DWG NO: U06-CM1A5R-034

REV: A
UNIT: mm
SCALE: 1=1
QUALITY SYMBOLS

RoHS Compliant

REVISIONS			
REV.	DESCRIPTION	DATE	DESIGN

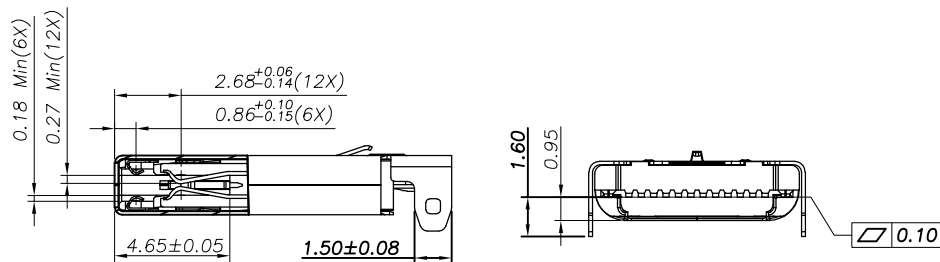

SECTION:A-A
SCALE 1:1

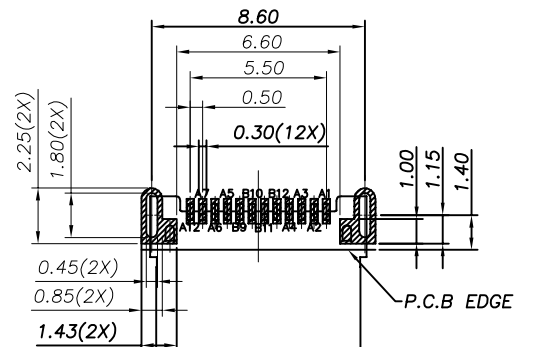

RECOMMENDED PCB LAYOUT(TOP VIEW)

TOLERANCE:±0.05

USB TYPE-C PIN ASSIGNMENTS

PIN NUMBER	SIGNAL NAME	PIN NUMBER	SIGNAL NAME
A1	GND	B12	GND
A2	SSTXp1	B11	SSRXp1
A3	SSTXn1	B10	SSRXn1
A4	Vbus	B9	Vbus
A5	CC1	B8	
A6	Dp1	B7	
A7	Dn1	B6	
A8		B5	
A9		B4	
A10		B3	
A11		B2	
A12	GND	B1	

Bestcreate Technology Limited

TOLERANCES UNLESS OTHERWISE SPECIFIED:

.X	±	0.30	X.'	±	3'
.XX	±	0.20	.X'	±	2'
.XXX	±	0.10	.XX'	±	1'

DESIGN: I. L DATE:

CHECKED: C. W DATE:

APPROVED: C. W DATE:

TITLE:
12P USB TYPE C MALE SMT CONNECTOR DIP SHELL

MATERILA: PART NO: U06-CM1A5R-034 SIZE: A4

FINSH: DWG NO: U06-CM1A5R-034

REV: A UNIT mm SCALE 1=1 QUALITY SYMBOLS

Website:www.bsc-elec.com
Email:bestcreate@bsc-elec.com

RoHS Compliant

REVISIONS			
REV.	DESCRIPTION	DATE	DESIGN

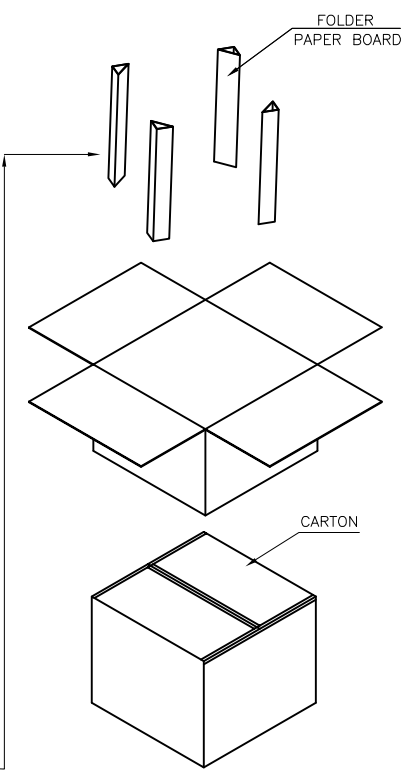
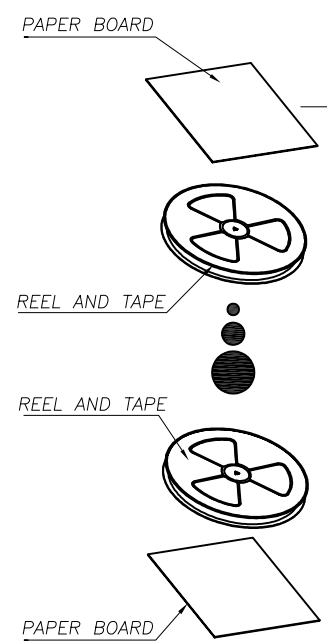
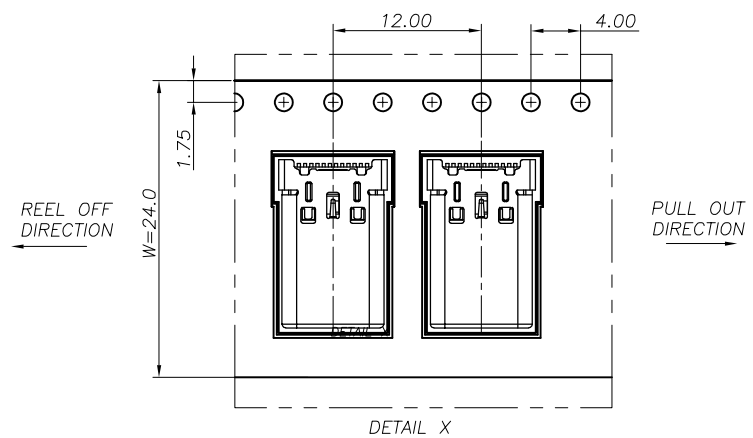
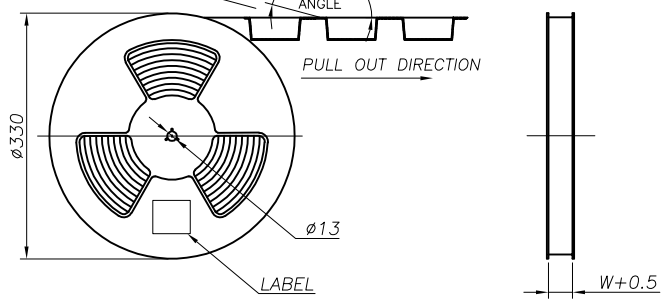
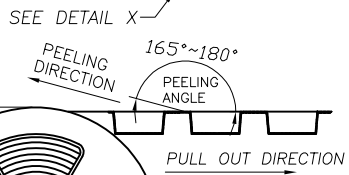
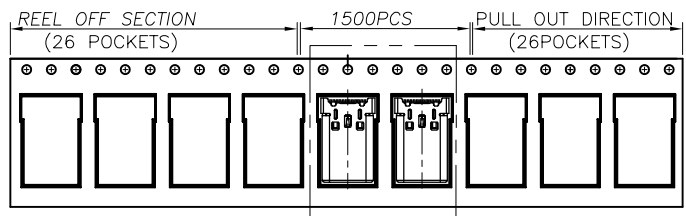

	REEL	CARTON
CONNECTOR (PCS)	1500	15000

Bestcreate Technology Limited

TOLERANCES UNLESS OTHERWISE SPECIFIED:

.X ± 0.30	X.* ± 3'
.XX ± 0.20	.X' ± 2'
.XXX ± 0.10	.XX' ± 1'

Website: www.bsc-elec.com
Email: bestcreate@bsc-elec.com

DESIGN: I. L DATE:

CHECKED: C. W DATE:

APPROVED: C. W DATE:

TITLE: 12P USB TYPE C MALE SMT CONNECTOR DIP SHELL

MATERILA: PART NO: U06-CM1A5R-034 SIZE: A4

FINSH: DWG NO: U06-CM1A5R-034

REV: A	UNIT mm	SCALE 1=1	QUALITY SYMBOLS
--------	---------	-----------	-----------------