

RoHS Compliant

REVISIONS			
REV.	DESCRIPTION	DATE	DESIGN

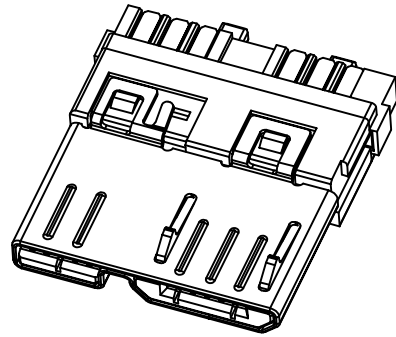

NOTE:

- MATERIAL SPECIFICATION:
 - HOUSING: PBT, UL94 V-0.
 - CONTACTS: COPPER ALLOY (C5191)
 - FRONT SHELL: STAINLESS STEEL (SUS304)
 - BACK COVER: LCP, UL94 V-0.
 - LATCH : SUS304
- PLATING SPECIFICATION:
 - TERMINAL:
 - Ni 50u" MIN. UNDER PLATED OVER ALL.
 - Au PLATED ON THE FUNCTIONAL AREA OF CONTACT. (GOLD PLATING THICKNESS FOLLOW THE P/N)
 - PLATING SPECIFICATIONS OF THE SOLDER AREA FOLLOW THE P/N
 - FRONT SHELL:
 - Ni 30u" MIN. UNDER PLATED OVER ALL.
- MECHANICAL PERFORMANCE,
 - INSERTION FORCE: 3.5Kgf MAX
 - REMOVAL FORCE: 1.02kgf MIN
 - DURABILITY: 10000 CYCLES.
- ELECTRICAL PERFORMANCE,
 - CURRENT RATING:
 - VBUS & GND PINS: 1.8A MAX.
 - OTHER PINS: 0.25A MAX.
 - LLCR:
 - VBUS & GND PINS : 30mΩ/PIN MAX.
 - ALL OTHER PINS: 50mΩ/PIN MAX.
 - LLCR MAX. CHANGE OF ALL PINS: 10mΩ.
 - INSULATION RESISTANCE: 100MΩ MIN
 - DIELECTRIC WITHSTAND VOLTAGE, AC 100V FOR 1 MINUTE.
- ENVIRONMENTAL PERFORMANCE:
 - OPERATING TEMPERATURE: -25°C~+85°C.

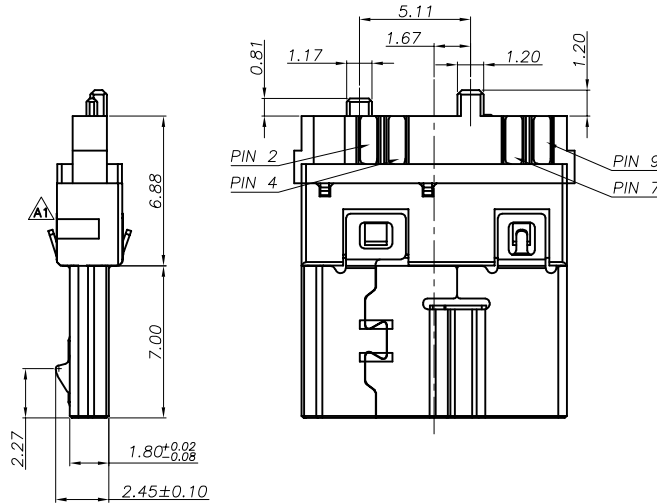
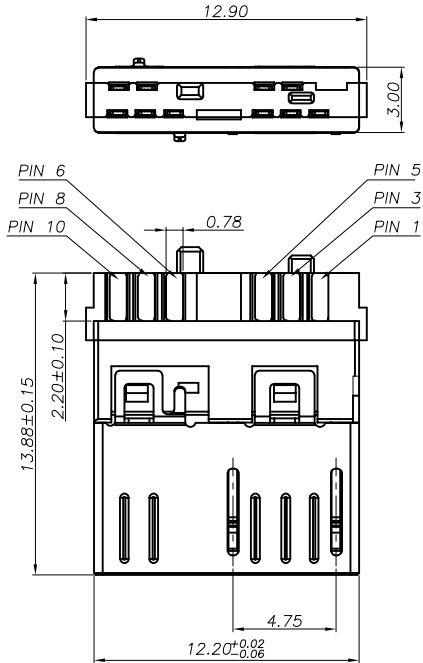

PART NO. INFORMATION

U04-B M X X 5 X - 002

PORT TYPE
B: TYPE B

GENDER
F: FEMALE
M: MALE

CONTACT PLATED
1: GOLD FLASH
2: GOLD 3U"
3: GOLD 5U"
4: GOLD 10U"
5: GOLD 15U"
6: GOLD 30U"

PACKAGE
T: TRAY B: BAG

HOUSING COLOR
2: WHITE
5: BLACK
9: BLUE

HOUSING MATERIAL
A: LCP B: PBT
C: PA9T D: PA6T
E: PA46 F: PA66

TABLE 1

ITEM	P/N	HOUSING COLOR	FUNCTIONAL AREA	SOLDER AREA	SHELL PLATING
3	U04-BM3B5T-002	PBT BLACK	Au:5u"	SN	G/F
2	U04-BM2B5T-002	PBT BLACK	Au:3u"	SN	G/F
1	U04-BM1B5T-002	PBT BLACK	Au:1u"	SN	NI

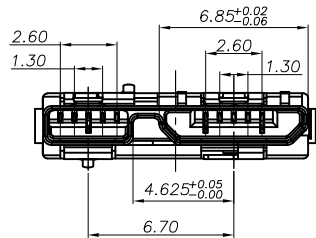

Bestcreate Technology Limited

TOLERANCES UNLESS OTHERWISE SPECIFIED:

X.	± 0.30	X.*	± 10"
.X	± 0.20	.X.*	± 8"
.XX	± 0.10	.XX.*	± 5"

DESIGN: I. L DATE: 2017. 3. 1

CHECKED: C. W DATE: 2017. 3. 1

APPROVED: C. W DATE: 2017. 3. 1

TITLE: MICRO USB 3.0 B MALE CONNECTOR FOR SOLDERING

MATERIAL: FINSH: PART NO: U04-BMXX5X-002 SIZE: A4

DWG NO: U04-BMXX5X-002

REV: A UNIT mm SCALE 1=1 QUALITY SYMBOLS

Website: www.bsc-elec.com Email: bestcreate@bsc-elec.com