

RoHS Compliant

REVISIONS			
REV.	DESCRIPTION	DATE	DESIGN

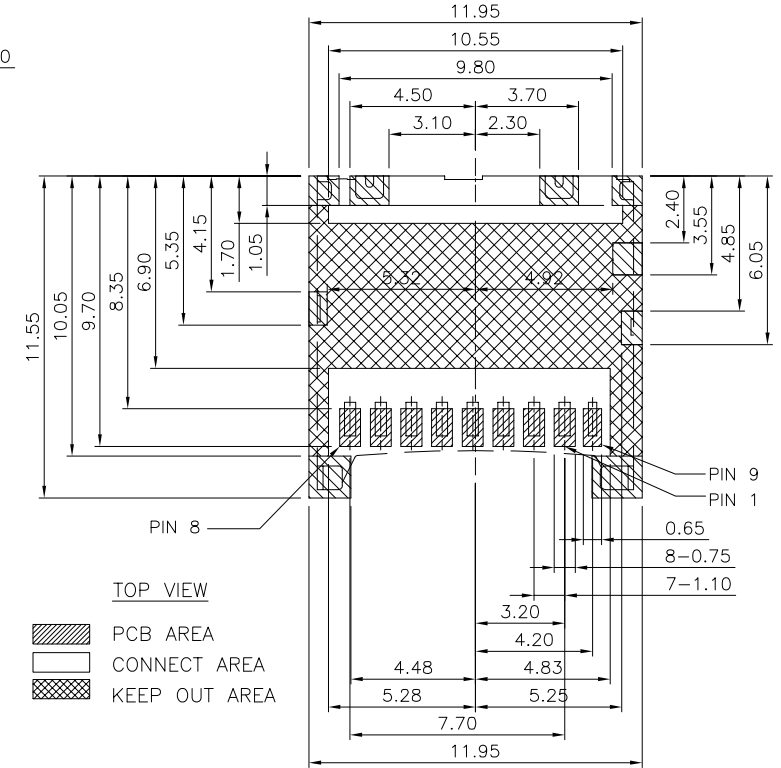
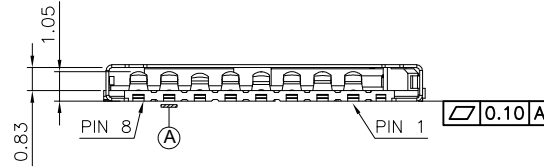
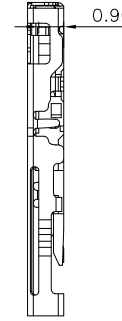
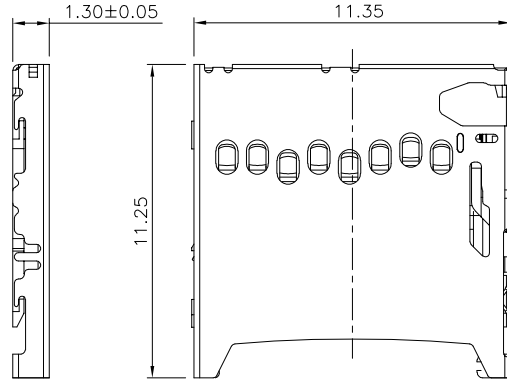
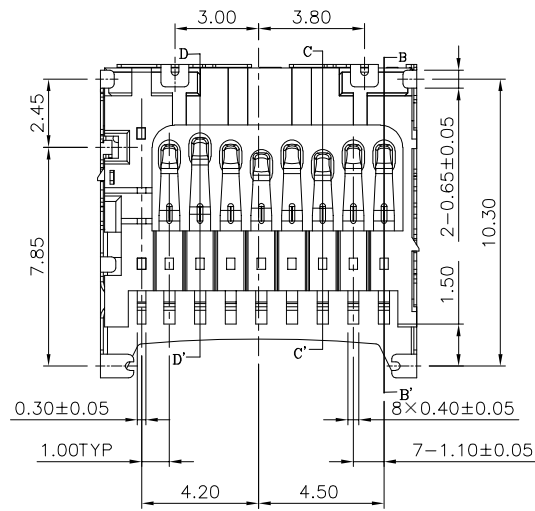

TOP VIEW

- PCB AREA
- CONNECT AREA
- KEEP OUT AREA

RECOMMEND PCB LAYOUT  
TOLERANCE: ±0.05

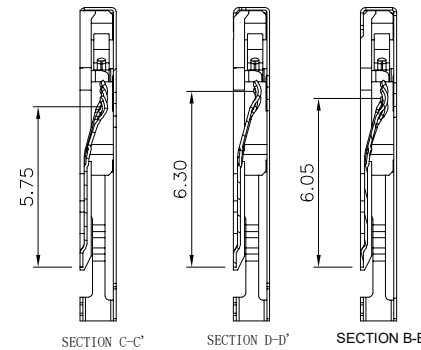

MICRO SD	
PIN1	DAT2
PIN2	CD/DAT3
PIN3	CMD
PIN4	VDD
PIN5	CLK
PIN6	VSS
PIN7	DAT0
PIN8	DAT1
PIN9	CD

**MATERIALS**

1. HOUSING :THERMOPLASTIC (UL 94V-0).
2. TERMINAL : COPPER ALLOY, PLATING SEE TABLE.
3. SHELL : SUS.

**SPECIFICATION**

1. CURRENT RATING : 0.5 A. MAX.
2. DIELECTRIC WITHSTANDING VOLTAGE : 500V AC R.M.S. FOR 1 MINUTE.
3. INSULATION RESISTANCE : 1000MΩ MIN.AT 500V DC.
4. CONTACT RESISTANCE : 100mΩ MAX.
5. OPERATING LIFE: 3000 CYCLES.
6. OPERATING TEMPERATURE : -40°C TO +85°C.
7. CIRCUIT DIAGRAM FOR CARD DETECT SWITCH  
CARD DETECT SWITCH (PIN 9)



**PART NO. INFORMATION**

**TFWF - 09 X X 5 R - 005**

- 09:9P
- CONTACT PLATED
- 1: GOLD FLASH
- 2: GOLD 3U"
- 3: GOLD 5U"
- 4: GOLD 10U"
- 5: GOLD 15U"
- 6: GOLD 30U"
- PACKAGE
- R: TAPE REEL
- HOUSING COLOR
- 2: WHITE
- 5: BLACK
- 9: NATURE
- HOUSING MATERIAL
- A: LCP B: PBT
- C: PA9T D: PA6T
- E: PA46 F: PA66

**Bestcreate Technology Limited**

TOLERANCES UNLESS OTHERWISE SPECIFIED:

.X	± 0.35	X.*	± 5*
.XX	± 0.25	.X.*	± 2*
.XXX	± 0.15	.XX.*	± 1*

Website:www.bsc-elec.com  
Email:bestcreate@bsc-elec.com

DESIGN: I. L DATE: 2017. 3. 1

CHECKED: C. W DATE: 2017. 3. 1

APPROVED: C. W DATE: 2017. 3. 1

TITLE: T-FLASH CARD 1. 3H

MATERIAL: PART NO: TFWF-09XX5R-005 SIZE: A4

FINISH: DWG NO: TFWF-09XX5R-005 SHEET: 1 OF 2

REV: A UNIT mm SCALE 1=1 QUALITY SYMBOLS

RoHS Compliant

REVISIONS			
REV.	DESCRIPTION	DATE	DESIGN

<图一>

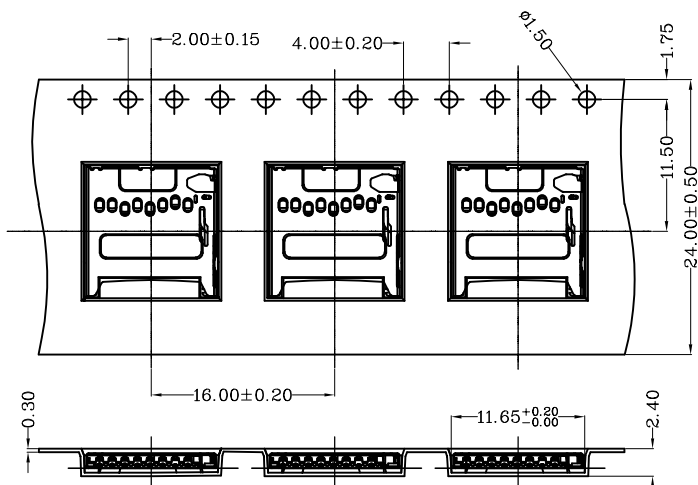

<图二>

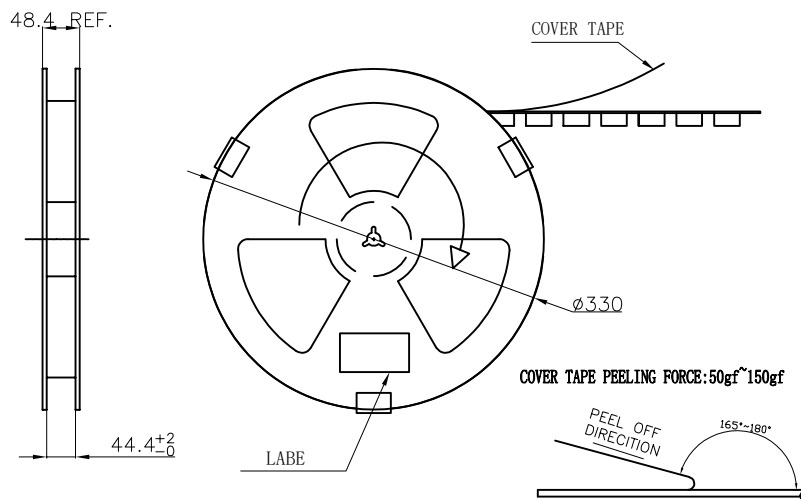

<TABLE 1> PACKAGING QUANTITY

QTY/REEL	REEL/CARTON	QTY/CARTON
1500	10	15000

<图三>

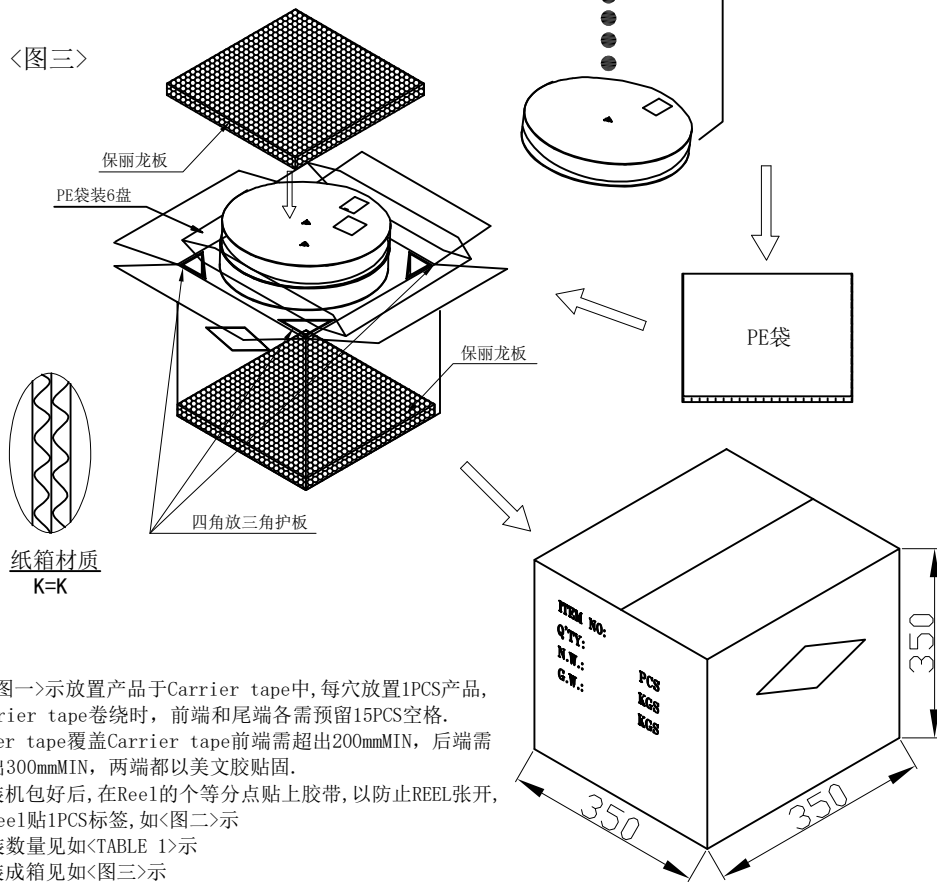

备注:

- 依<图一>示放置产品于Carrier tape中,每穴放置1PCS产品,Carrier tape卷绕时,前端和尾端各需预留15PCS空格。
- Cover tape覆盖Carrier tape前端需超出200mmMIN,后端需留出300mmMIN,两端都以美文胶贴固。
- 包装机包好后,在Reel的个等分点贴上胶带,以防止REEL张开,每Reel贴1PCS标签,如<图二>示
- 包装数量见如<TABLE 1>示
- 包装成箱见如<图三>示  
箱底放保丽龙板,再将PE袋(10个Reel盘)放入箱内,四角各放一个三角护板,最上层再放上保丽龙板。
- 封箱,在封好的纸箱侧面中间位置贴上出货标签。

**Bestcreate Technology Limited**

TOLERANCES UNLESS OTHERWISE SPECIFIED:

.X	± 0.35	X.*	± 5'
.XX	± 0.25	.X*	± 2'
.XXX	± 0.15	.XX*	± 1'

Website: www.bsc-elec.com  
Email: bestcreate@bsc-elec.com

DESIGN: I.L DATE: 2017.3.1

CHECKED: C.W DATE: 2017.3.1

APPROVED: C.W DATE: 2017.3.1

TITLE: T-FLASH CARD 1.3H 包装图

MATERIAL:	PART NO: TFWF-09XX5R-005	SIZE: A4
FINISH:	DWG NO: TFWF-09XX5R-005	SHEET: 2 OF 2

REV: A	UNIT: mm	SCALE: 1=1	QUALITY SYMBOLS
--------	----------	------------	-----------------