

RoHS Compliant

REVISIONS			
REV.	DESCRIPTION	DATE	DESIGN

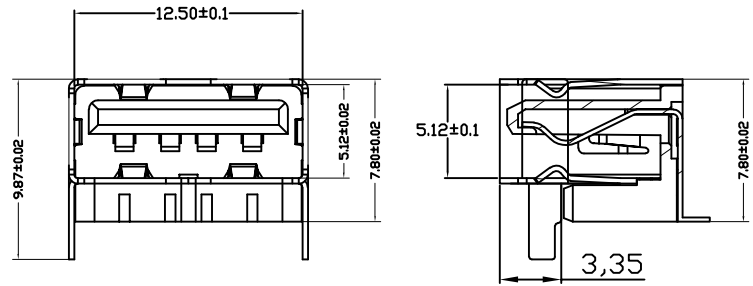

SECTION A-A

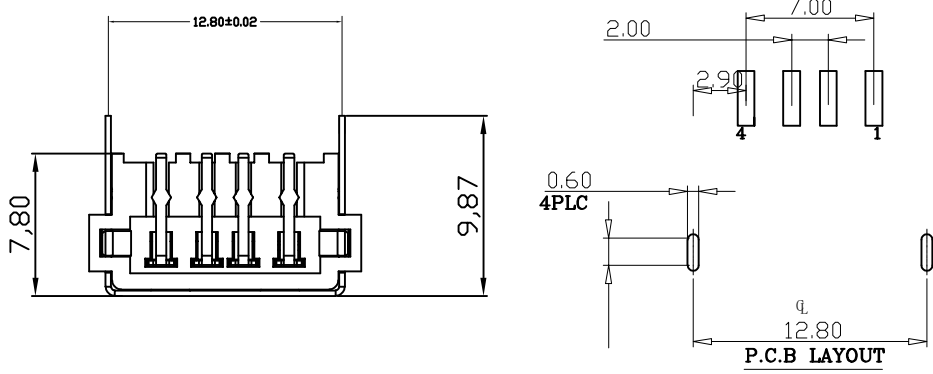
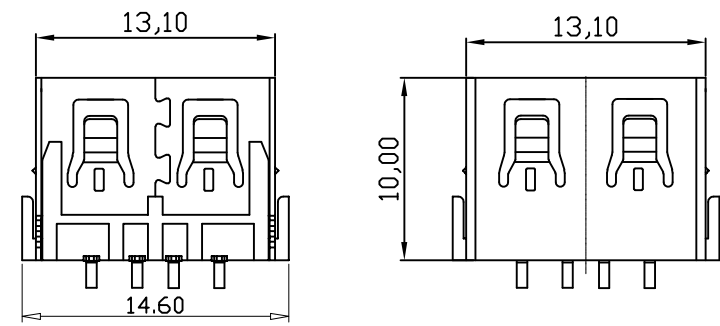

规格说明 Specifications:

电气特性 Electrical:

- 额定电流: Current Rating
1.5A/contact terminal
- 额定电压: Voltage Rating
30V DC
- 接触电阻: Contact Resistance
30 milliohms MAX
- 耐电压: Dielectric Withstanding Voltage:
500 V AC AT Sea Level
- 绝缘电阻: Insulation Resistance:
1000MEGA ohms MIN

物理性能 Mechanical:

- 插拔力: Connector Mate and Unmate Force
Mate force: 3.57kgf(MAX)
Unmate force: 1.02kgf(MIN)
- 端子保持力: Terminal Retention
1.2kgf(MIN)

原材料 Material:

- 塑胶 Housing:
High Temperature Thermoplastics,
UL 94V-0 PBT White/Black
- 端子 Contact: Copper Alloy C2680
- 外壳 Shell: Copper Alloy C2680/SPCC

电镀 Finish:

- 端子 Contact: Plated Gold in Mating Area;
Tin On Solder Talls
- 外壳 Shell:
Nickel Plating

PART NO. INFORMATION

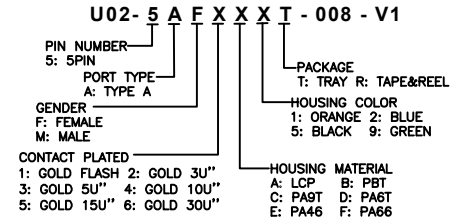

Bestcreate Technology Limited

TOLERANCES UNLESS OTHERWISE SPECIFIED:					
.X	±	0.30	X'	±	5'
.XX	±	0.20	.X'	±	2'
.XXX	±	0.10	.XX'	±	1'

Website: www.bsc-elec.com
Email: bestcreate@bsc-elec.com

DESIGN:	DATE:
I. L	2017. 3. 1
CHECKED:	DATE:
C. W	2017. 3. 1
APPROVED:	DATE:
C. W	2017. 3. 1

TITLE:		
USB 2.0 A FEMALE CONNECTOR SHORT BODY 10.0 H=7.8		
MATERIAL:	PART NO:	SIZE:
	U02-5AFXXXT-008-V1	A4
FINISH:	DWG NO:	
	U02-5AFXXXT-008-V1	

REV:	UNIT	SCALE	QUALITY SYMBOLS
A	mm	1=1	