

RoHS Compliant

REVISIONS			
REV.	DESCRIPTION	DATE	DESIGN

A

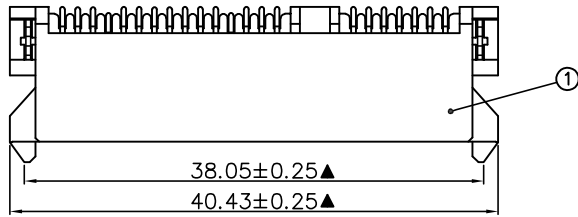

B

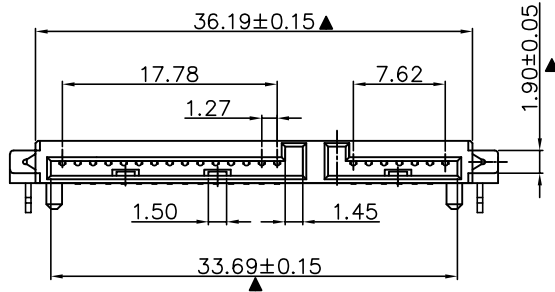

C

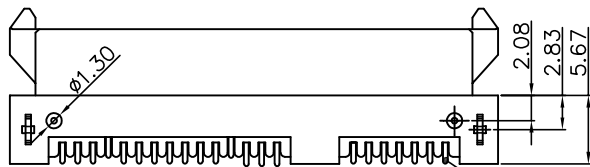

D

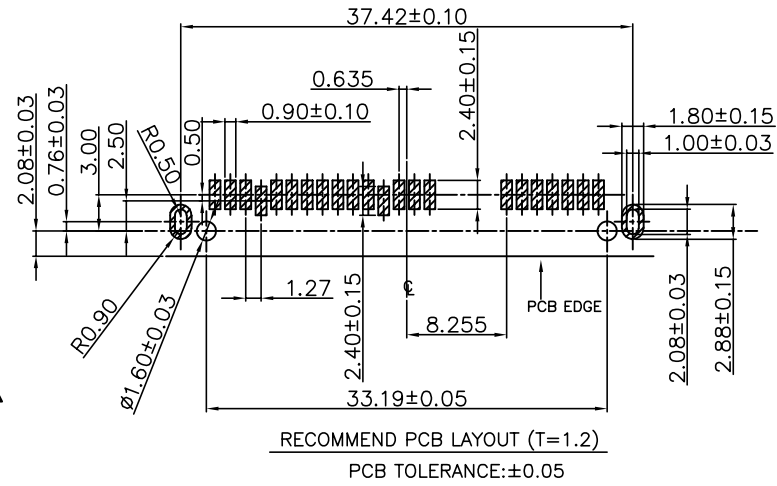
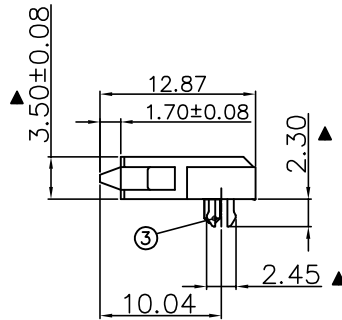
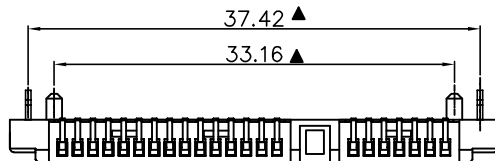

PART NO. INFORMATION

S715 - F X A 5 T -004

GENDER
F: FEMALE
M: MALE

CONTACT PLATED
1: GOLD FLASH/TIN
2: 15U" GOLD/TIN
3: 30U" GOLD/TIN

PACKAGE
T: TRAY
R: TAPE REEL
HOUSING COLOR
5: BLACK
HOUSING MATERIAL
A: LCP

SPECIFICATION:

1.MATERIAL:
HOUSING: LCP UL 94V-0
COLOR:BLACK
CONTACT: PHOSPHOR BRONZE C5191R-H,T=0.25mm
PEG: BRASS C2680R-H,T=0.45mm
2.FINISH:
CONTACT: 1u" GOLD/TIN PLATING ON CONTACT AREA
100u" MIN. TIN PLATING ON SOLDER TAILS
50u" MIN. NICKEL UNDERPLATING OVER ALL
PEG:100u" MIN. TIN PLATING ON SOLDER TAILS
50u" MIN. NICKEL UNDERPLATING OVER ALL

NO.	DESCRIPTION	MATERIAL	COLOR	REMARK
3	Board lock	Brass C2680		Gold/Ni Plated
2	Terminal	Pho.Bronze C5191R-H		Gold/Tin Plated
1	Housing	High Temp	Black	UL 94V-0

Bestcreate Technology Limited

REV: A	UNIT: mm	SCALE: 1=1	QUALITY SYMBOLS
--------	----------	------------	-----------------

TOLERANCES UNLESS OTHERWISE SPECIFIED:			
X.	± 0.30	X.*	± 3*
.X	± 0.20	.X.*	± 2*
.XX	± 0.15	.XX.*	± 1*
Website: www.bsc-elec.com			
E-mail: bestcreate@bsc-elec.com			

DESIGN: I. L	DATE: 2017. 3. 1
CHECKED: C. W	DATE: 2017. 3. 1
APPROVED: C. W	DATE: 2017. 3. 1

TITLE: SATA 7+15P 母座 SMT H:3.50 板上型		
MATERIAL:	PART NO: S715-FXA5T-004	SIZE: A4
FINSH:	DWG NO: S715-FXA5T-004	SHEET: 1 OF 1