

RoHS Compliant

| REVISIONS |             |      |        |
|-----------|-------------|------|--------|
| REV.      | DESCRIPTION | DATE | DESIGN |
|           |             |      |        |

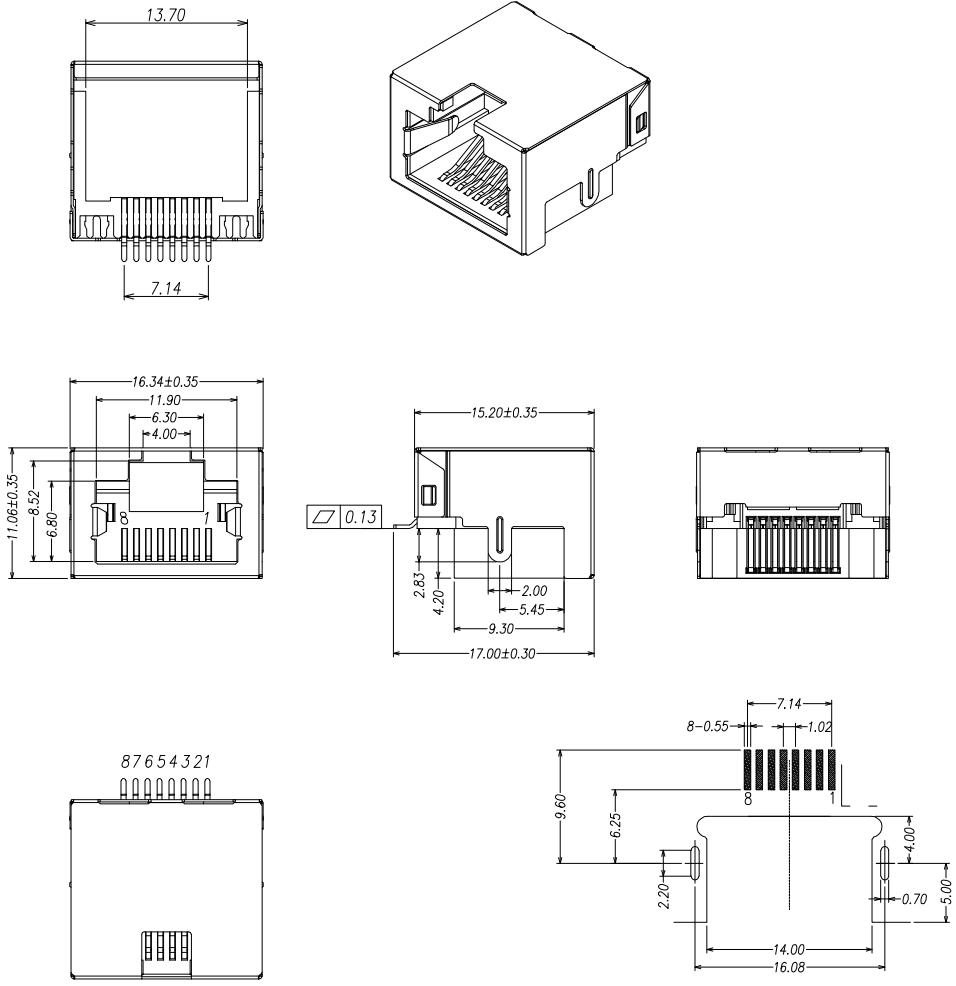

**SPECIFICATION NOTES:**

**ELECTRICAL:**

- VOLTAGE RATING: 125 VAC RMS
- CURRENT RATING: 1.5 AMP
- CONTACT RESISTANCE: 40mΩ MAX.
- INSULATION RESISTANCE: 1000MΩ MIN. AT500V DC.
- DIELECTRIC STRENGTH: 1000 V AC OR 1500V DC RMS AT 0.5mA 50 Hz / 60 Hz FOR 1MINUTE

**MECHANICAL:**

- HOUSING:LCP BLACK, UL 94V-0
- CONTACT:PHOSPHOR BRONZE T=0.30MM
- PLATING:FU GOLD PLATING AT CONTACT AREA, MATTE TIN AT TAIL 100U MIN., NICKEL 30U MIN. OVER ALL.
- SHELL:BRASS T=0.20
- OPERATING LIFE:750 CYCLES MIN.
- MATING/UNMATING FORCE: 30N/3.06KgF MAX.
- RETENTION STRENGTH:50N OR 30N MIN.FOR 60S±5S

**ENVIRONMENTAL:**

- STORAGE:-40°C TO +85°C RELATIVE HUMIDITY<80%
- GUARANTEE PERIOD:12 MONTHS
- OPERATION: -40°C TO +85°C
- MANUAL SOLDERING PARAMETERS:24H IR TEMPERATURE: 255±5°C 5~10 SECONDS.

**PART NO. INFORMATION**

**RJ01- X 5 0 X - 076**

CONTACT PLATED

- 1: G/F
- 2: AU 3U"
- 3: AU 6U"
- 4: AU 15U"
- 5: AU 30U"

PACKAGE  
R: TAPE REEL  
T: TRAY

Recommend PCB Layout  
(Jack Top View)  
Tolerance: ±0.05mm

**Bestcreate Technology Limited**

TOLERANCES UNLESS OTHERWISE SPECIFIED:

|      |        |      |      |
|------|--------|------|------|
| .X   | ± 0.35 | X.*  | ± 3* |
| .XX  | ± 0.25 | .X*  | ± 2* |
| .XXX | ± 0.15 | .XX* | ± 1* |

Website:www.bsc-elec.com  
Email:bestcreate@bsc-elec.com

|            |                 |
|------------|-----------------|
| DESIGN:    | DATE:           |
| <b>I.L</b> | <b>2017.3.1</b> |
| CHECKED:   | DATE:           |
| <b>C.W</b> | <b>2017.3.1</b> |
| APPROVED:  | DATE:           |
| <b>C.W</b> | <b>2017.3.1</b> |

|  |                           |             |
|--|---------------------------|-------------|
| TITLE:<br>MID-MOUNT 4.2MM RJ45<br>CONNECTOR SMD TYPE |                           |             |
| MATERILA:  | PART NO:<br>RJ01-X50X-076 | SIZE:<br>A4 |
| FINISH:  | DWG NO:<br>RJ01-X50X-076  |             |

|           |            |              |                 |
|-----------|------------|--------------|-----------------|
| REV:<br>A | UNIT<br>mm | SCALE<br>1=1 | QUALITY SYMBOLS |
|-----------|------------|--------------|-----------------|