

RoHS Compliant

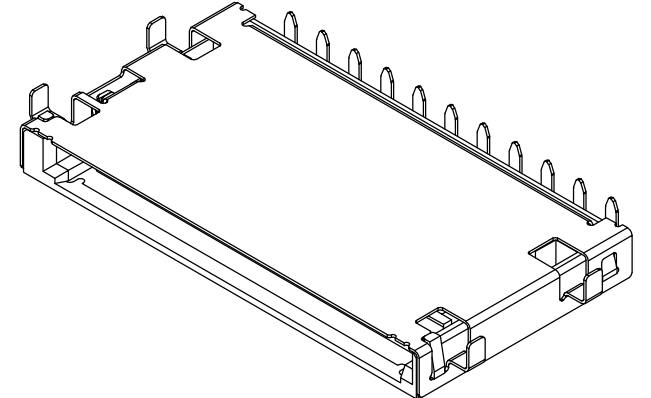
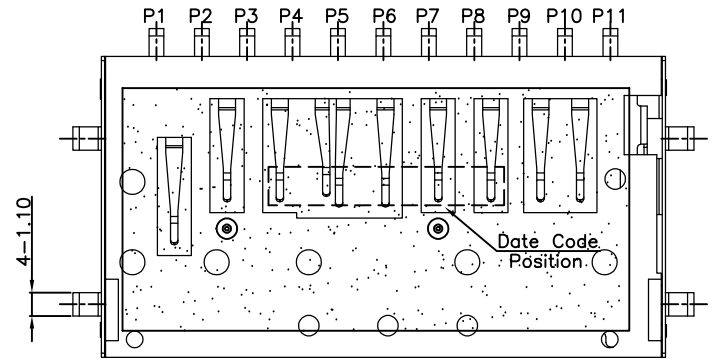
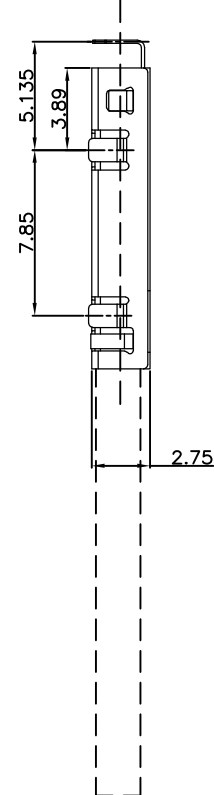
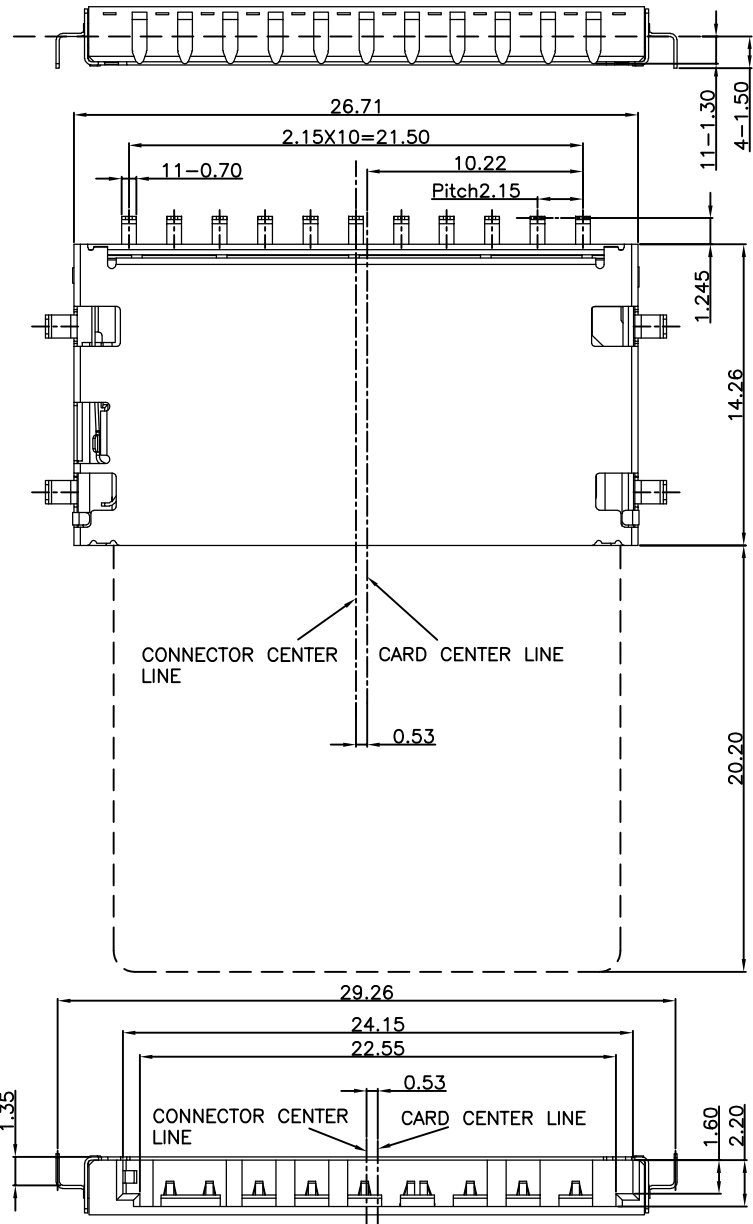

Bestcreate Technology Limited

TOLERANCES UNLESS OTHERWISE SPECIFIED:

.X	±	0.35	X.*	±	5*
.XX	±	0.25	.X*	±	2*
.XXX	±	0.15	.XX*	±	1*

Website: www.bsc-elec.com
 Email: bestcreate@bsc-elec.com

DESIGN: I.L
 DATE: 2017.3.1

CHECKED: C.W
 DATE: 2017.3.1

APPROVED: C.W
 DATE: 2017.3.1

TITLE: SD N/P板下DIP沉板 1.35

MATERIAL: PART NO: SD-11XX5R-002 SIZE: A4

FINISH: DWG NO: SD-11XX5R-002 SHEET: 1 OF 3

REV: A
 UNIT: mm
 SCALE: 1=1
 QUALITY SYMBOLS:

RoHS Compliant

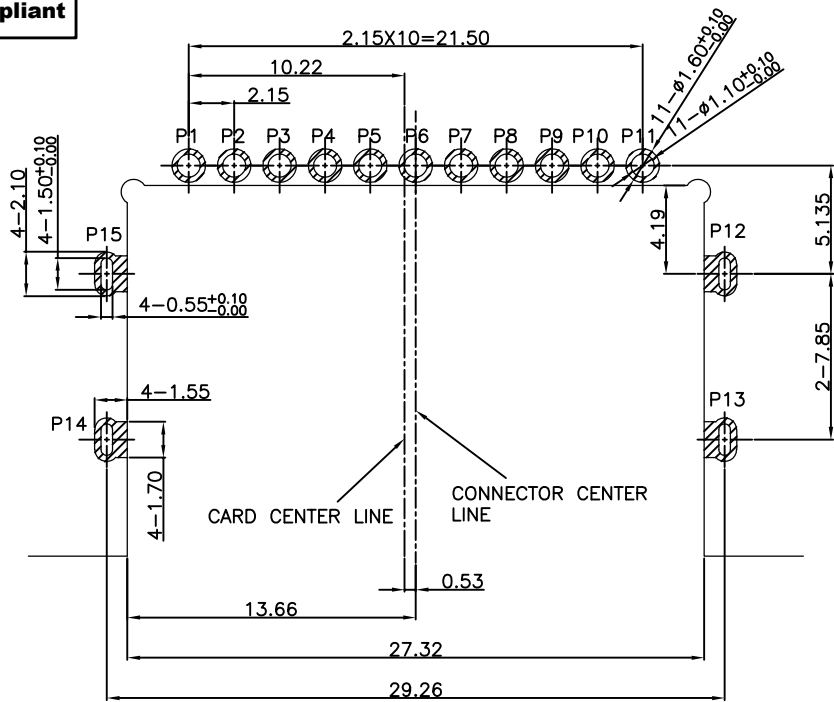

Specification

- *Electrical Characteristics:
 - Contact Current Rating:0.5 Amperes.
 - Dielectric Withstanding Voltage:AC500V r.m.s.
 - Insulation Resistance:1000 MΩ Minimum.
 - Contact Resistance:100 mΩ Maximum.
- *Environmental:
 - Operating Temperature:-25°C~+85°C.
- *Mechanical Characteristics:
 - Mating Cycles:10,000 Cycles Insertion/Extraction
 - Card Push Insertion/Out Force:1kgf Maximum.
 - Contact Retention Force:0.15kgf Minimum.
- *Material:
 - Insulator:HI-Temp Plastic UL 94V-0 Rated.
 - Contact:Copper Alloy.
 - Shell:Stainless Steel.

RECOMMEND P.C.B LAYOUT TOLERANCE ±0.05



PAD



No trace , no test point, no via hole, no ground area

WITHOUT CARD		CARD INSERTED:LOCK		CARD INSERTED:UNLOCK	
W/P	GND	W/P	GND	W/P	GND
C/D	VSS1	C/D	VSS1	C/D	VSS1

Pin Define

Connector Pin No.	SD Card Pin No.	Pin Define
P1	P9	DAT2
P2	P1	DAT3
P3	P2	CMD
P4		CD
P5	P3	VSS1
P6	P4	VDD
P7	P5	CLK
P8	P6	VSS2
P9	P7	DATO
P10	P8	DAT1
P11		W/P
P12~P15		GND

PART NO. INFORMATION

SD -11 X X 5 R - 002

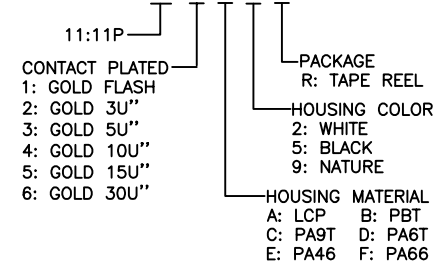

Bestcreate Technology Limited

TOLERANCES UNLESS OTHERWISE SPECIFIED:

.X	±	0.35	X.*	±	5*
.XX	±	0.25	.X*	±	2*
.XXX	±	0.15	.XX*	±	1*

Website:www.bsc-elec.com
Email:bestcreate@bsc-elec.com

DESIGN: I.L DATE: 2017. 3. 1

CHECKED: C.W DATE: 2017. 3. 1

APPROVED: C.W DATE: 2017. 3. 1

TITLE: SD N/P板下DIP沉板 1.35

MATERIAL:	PART NO:	SIZE:
FINSH:	SD-11XX5R-002	A4
DWG NO:	SD-11XX5R-002	SHEET: 2 OF 3

REV:	UNIT	SCALE	QUALITY SYMBOLS
A	mm	1=1	

RoHS Compliant

<图一>

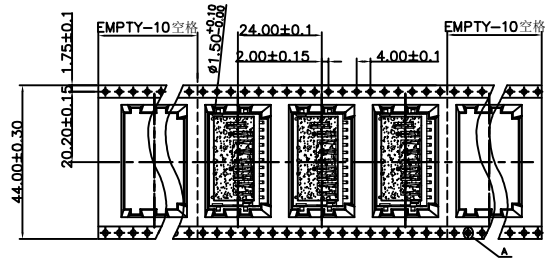

<TABLE 1> PACKAGING QUANTITY

QTY/REEL	REEL/CARTON	QTY/CARTON
600	6	3600

<图三>

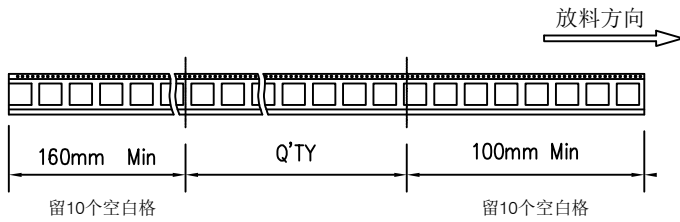
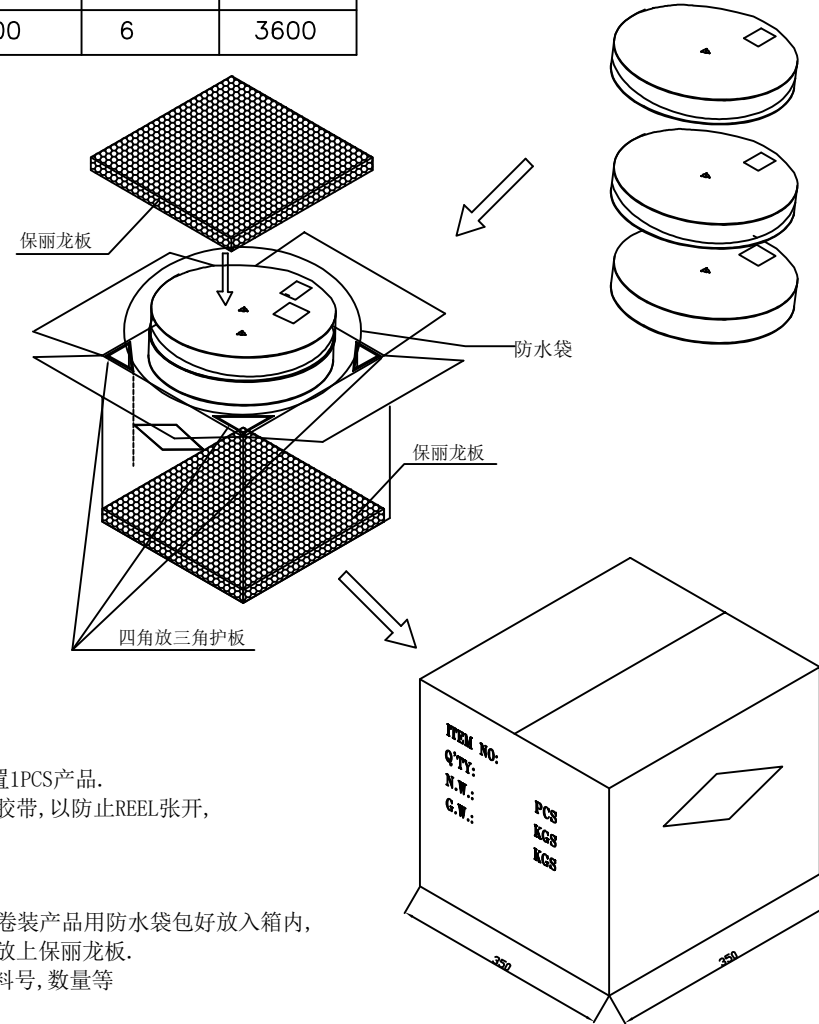

<图二>

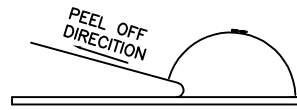
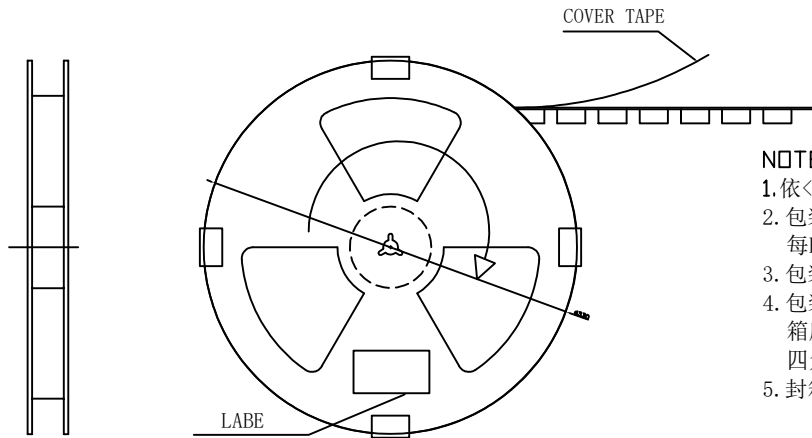

NOTE:

- 依<图一>示放置产品于下载中, 每穴放置1PCS产品.
- 包装机包好后, 在REEL的个等分点贴上胶带, 以防止REEL张开, 每REEL贴1PCS标签, 如<图二>示
- 包装数量见如<TABLE 1>示
- 包装成箱见如<图三>示
箱底放保丽龙板, 再依次将指定数量的卷装产品用防水袋包好放入箱内, 四角分别放入四个三角护板, 最上层再放上保丽龙板.
- 封箱, 在封好的纸箱上按客户要求写上料号, 数量等

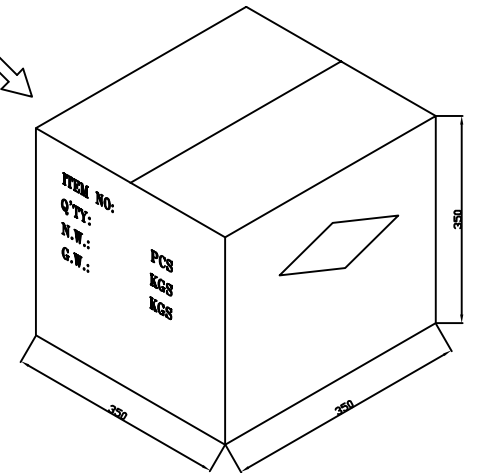

Bestcreate Technology Limited

TOLERANCES UNLESS OTHERWISE SPECIFIED:

.X	±	0.35	X.*	±	5*
.XX	±	0.25	.X*	±	2*
.XXX	±	0.15	.XX*	±	1*

Website: www.bsc-elec.com
Email: bestcreate@bsc-elec.com

DESIGN: I.L DATE: 2017. 3. 1

CHECKED: C.W DATE: 2017. 3. 1

APPROVED: C.W DATE: 2017. 3. 1

TITLE: SD N/P板下DIP沉板 1.35 包装规范

MATERIAL: PART NO: SD-11XX5R-002 SIZE: A4

FINISH: DWG NO: SD-11XX5R-002 SHEET: 3 OF 3

REV: A UNIT mm SCALE 1=1 QUALITY SYMBOLS