

RoHS Compliant

REVISIONS			
REV.	DESCRIPTION	DATE	DESIGN

DESCRIPTION OF PRODUCTS:

1. APPLY TO THE CONNECTION OF COMMUNICATION SOCKET BETWEEN EQUIPMENT AND WORKING AREA FOR SIGNAL TRANSMISSION
2. INTERNAL STRUCTURE IS COMPACT, BRIEF OUTWARD, ELEGANT APPEARANCE.
3. LIFETIME: 750CYCLES
4. CONTACT RESISTANCE $\leq 2.5\text{M}\Omega$
5. PRESSURE RESISTANCE: DC700V 1MIN
6. INSULATION RESISTANCE $\geq 1000\Omega$
7. HOUSING: ABS ROHS
8. TERMINAL: CAROBRONZE T=0.35MM
9. FLANGE WITH HOLE: ZINC ALLOY WITH NICKEL PLATING ON SURFACE

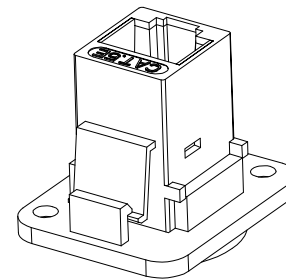
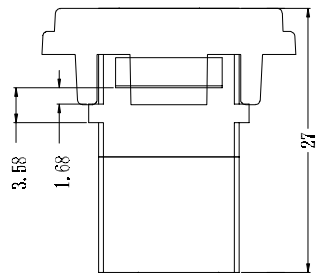
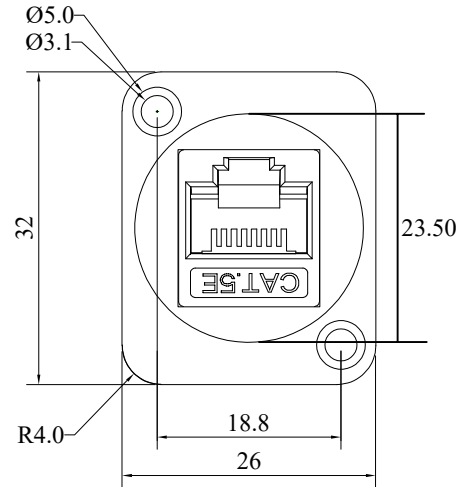
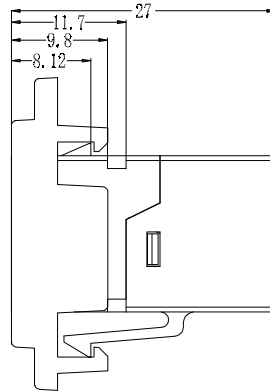
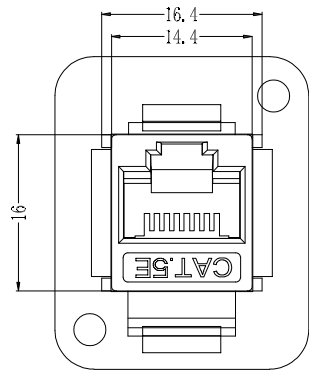

Bestcreate Technology Limited

TOLERANCES UNLESS OTHERWISE SPECIFIED:

X.	± 0.35	X.*	± 3'
.X	± 0.30	.X*	± 2'
.XX	± 0.25	.XX*	± 1'

Website: www.bsc-elec.com
 Email: bestcreate@bsc-elec.com

DESIGN: I. L DATE: 2017. 3. 1

CHECKED: C. W DATE: 2017. 3. 1

APPROVED: C. W DATE: 2017. 3. 1

TITLE: RJ45 8P8C CAT. 5 5E UTP CONNECTOR DUAL PORT
 PANEL MOUNT, L=27MM

MATERILA:	PART NO: UTP-S-5866-CAT-5E-27MM	SIZE: A4
FINSH:	DWG NO: UTP-S-5866-CAT-5E-27MM	

REV: A	UNIT mm	SCALE 1=1	QUALITY SYMBOLS	
--------	---------	-----------	-----------------	--