

RoHS Compliant

REVISIONS			
REV.	DESCRIPTION	DATE	DESIGN

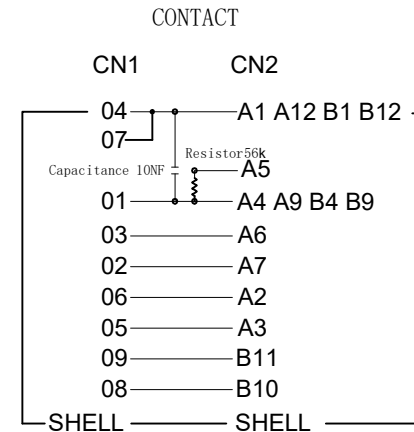
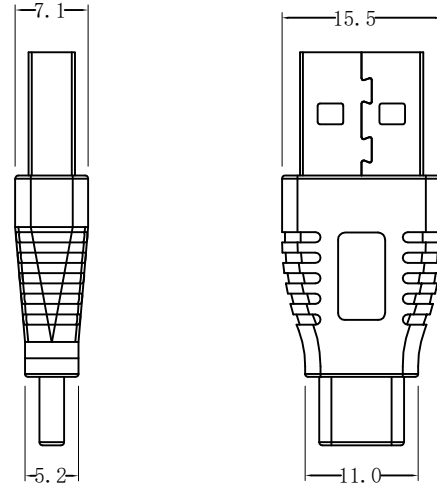
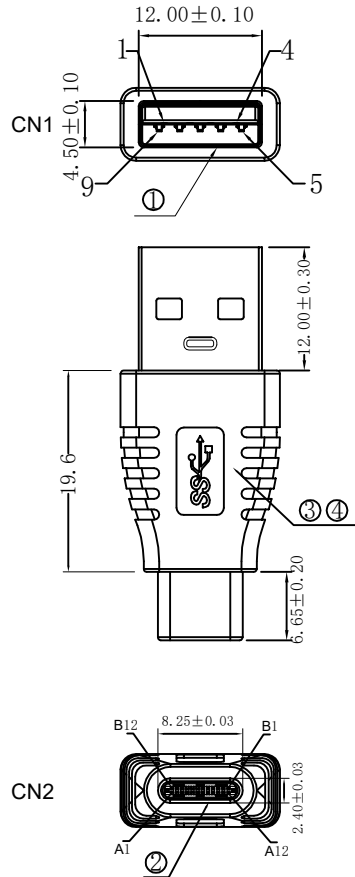

NOTES:

- 100% open short test condition;
- Conductor Resistance $\leq 5 \Omega$, insulation resistance $\geq 10M \Omega$.
High voltage test, DC 300V/10mS.
- Support Power Charging、Data Transfer.
- PCB Board Connection.

4	Outer Mold	PVC 45P BLACK	5.09.02-1	3.4G
3	Internal Mold	PCB T=0.8MM 1*Resistor56K 1*Capacitance 10NF	5.12.283	1PCS
2	Connector	USB TYPE CM SHELL NICKEL PLATED PIN G/F	5.03.69	1PCS
1	Connector	USB 3.0 AM SHELL NICKEL PLATED PIN G/F BLUE	5.03.26	1PCS
NO	NAME	MATERIAL	NO	QTY

Bestcreate Technology Limited

TOLERANCES UNLESS OTHERWISE SPECIFIED:

X.	± 0.50	X.*	± 5°
.X	± 0.30	.X*	± 2°
.XX	± 0.10	.XX*	± 1°

DESIGN: I. L DATE: 2017.3.1

CHECKED: C. W DATE: 2017.3.1

APPROVED: C. W DATE: 2017.3.1

TITLE: USB3.0 AM TO TYPE CF 180°

MATERILA:	PART NO: AD30AMCF-010	SIZE: A4
FINISH:	DWG NO: AD30AMCF-010	

REV: A	UNIT mm	SCALE 1=1	QUALITY SYMBOLS	
--------	---------	-----------	-----------------	--

Website: www.bsc-elec.com
Email: bestcreate@bsc-elec.com