

RoHS Compliant

REVISIONS			
REV.	DESCRIPTION	DATE	DESIGN

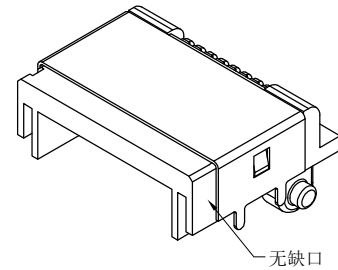

- SPECIFICATION**
- VOLTAGE RATING: 150 VAC RMS.
 - CURRENT RATING: 1.5 AMP
 - CONTACT RESISTANCE: 40 mΩ MAX
 - INSULATION RESISTANCE: 500MΩ MIN.
 - WITHSTAND VOLTAGE: AC1000V RMS 60s.
 - OPERATING TEMPERATURE: -40°C~+80°C

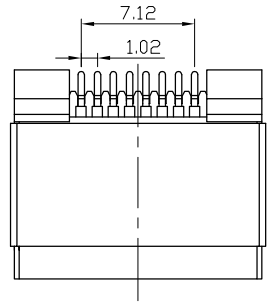
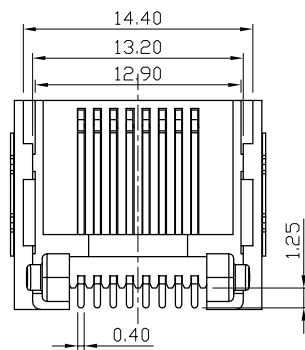
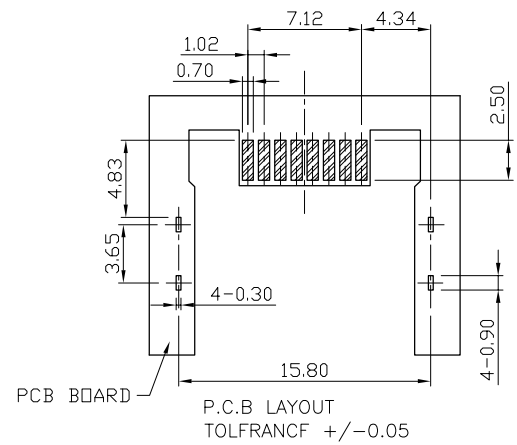
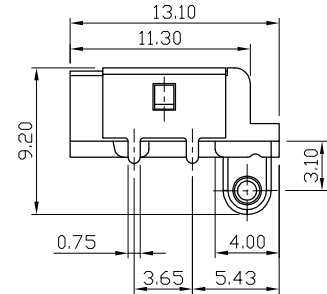
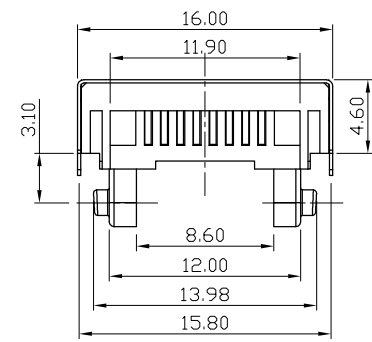

PART NO. INFORMATION

RJ01- X 5 0 X - 008

CONTACT PLATED
 1: G/F 2: AU 30"
 3: AU 5U" 4: AU 10U"
 5: AU 15U" 6: AU 30U"
PACKAGE
 R: TAPE REEL
 T: TRAY

c	SHELL	1	BRASS T=0.2mm	Ni PALTING
b	TERMINAL	8	PHOSPHOR BRONZE	Au PALTING
a	HOUSING	1	LCP UL94V-0	BLACK
NO.	PART NAME	Q'TY	MATERIAL	PLATING & COLOR

Bestcreate Technology Limited

TOLERANCES UNLESS OTHERWISE SPECIFIED:			
.X	± 0.30	X'	± 3'
.XX	± 0.20	.X'	± 2'
.XXX	± 0.10	.XX'	± 1'
Website: www.bsc-elec.com			
Email: bestcreate@bsc-elec.com			

DESIGN:	DATE:
I. L	2017. 3. 1
CHECKED:	DATE:
C. W	2017. 3. 1
APPROVED:	DATE:
C. W	2017. 3. 1

TITLE:		
RJ45 8P8C CONNECTOR SMT TYPE		
MATERILA:	PART NO:	SIZE: A4
	RJ01-X50X-008	
FINSH:	DWG NO:	
	RJ01-X50X-008	

REV: A	UNIT mm	SCALE 1=1	QUALITY SYMBOLS
--------	---------	-----------	-----------------