

RoHS Compliant

REVISIONS			
REV.	DESCRIPTION	DATE	DESIGN

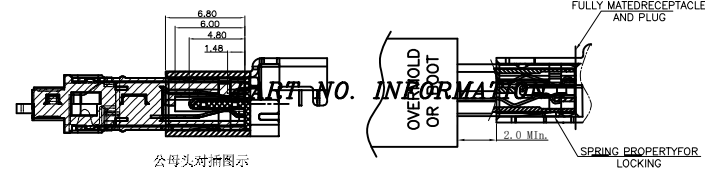
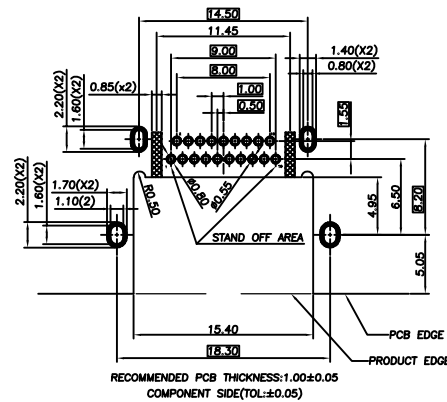
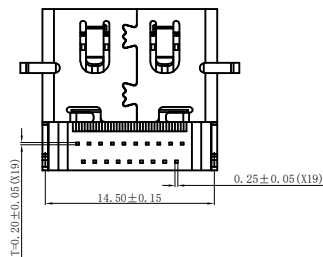
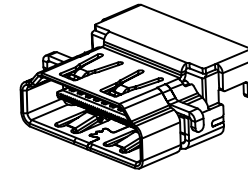
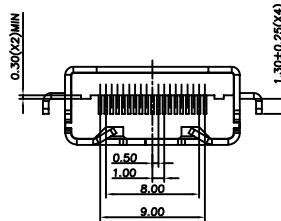
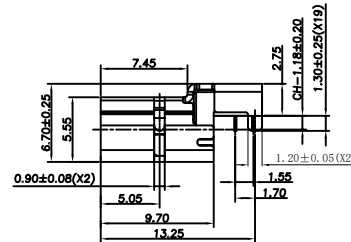
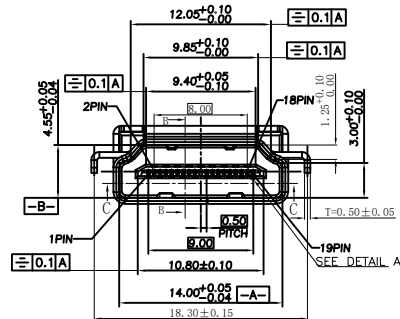
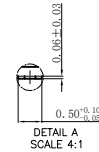
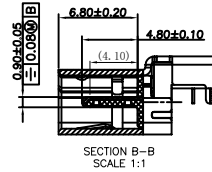
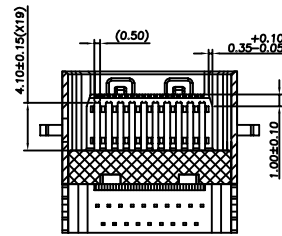
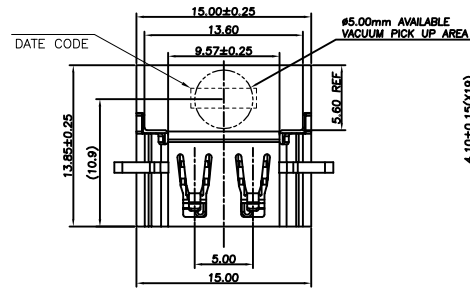

公母头对插图示

HD01-A F X X 5 R - 024

PORT TYPE  
A: TYPE A

GENDER  
F: FEMALE  
M: MALE

PACKAGE  
R: TAPE REEL

HOUSING COLOR  
2: WHITE  
5: BLACK  
9: NATURE

HOUSING MATERIAL  
A: LCP B: PBT  
C: PA9T D: PA6T  
E: PA46 F: PA66

CONTACT PLATED  
1: GOLD FLASH  
2: GOLD 3U''  
3: GOLD 5U''  
4: GOLD 10U''  
5: GOLD 15U''  
6: GOLD 30U''

PIN	SIGNAL ASSIGNMENT	PIN	SIGNAL ASSIGNMENT	PIN	SIGNAL ASSIGNMENT
1	TMDS DATA+	8	TMDS DATA SHIELD	15	SCL
2	TMDS DATA2 SHIELD	9	TMDS DATA-	16	SDA
3	TMDS DATA2-	10	TMDS CLOCK+	17	DDC/CEC GROUND
4	TMDS DATA1+	11	TMDS CLOCK + SHIELD	18	+9V POWER
5	TMDS DATA1 SHIELD	12	TMDS CLOCK-	19	HOT PLUG DETECT
6	TMDS DATA1-	13	CEC		
7	TMDS DATA0+	14	URLP/NEK+		

C	SHELL	1	MATAL/SEE TABLE A
B	TERMINAL	19	COPPER YELLOW/SEE TABLE A
A	HOUSING	1	HTERNOPLASTIC UL94V-0 BLACK
NO	PART NAME	QTY	MATERIAL PLATING & COLOR

Bestcreate Technology Limited

TOLERANCES UNLESS OTHERWISE SPECIFIED:

X.	± 0.50	X.*	± 3"
.X	± 0.30	.X*	± 2"
.XX	± 0.20	.XX*	± 1"

Tel/Whatsapp: 0086-13712299763  
Skype: belle.wu3340

DESIGN: I.L DATE: 2017.3.1

CHECKED: C.W DATE: 2017.3.1

APPROVED: C.W DATE: 2017.3.1

TITLE: HDMI A TYPE 19PIN H=6.75 CH=-1.95MM, REC RVS DIP TYPE

MATERILA:	PART NO:	SIZE:
FINSH:	HDO1-AFXX5R-024	A4
	DWG NO:	
	HDO1-AFXX5R-024	

REV: A	UNIT mm	SCALE 1=1	QUALITY SYMBOLS
--------	---------	-----------	-----------------

RoHS Compliant

REVISIONS			
REV.	DESCRIPTION	DATE	DESIGN

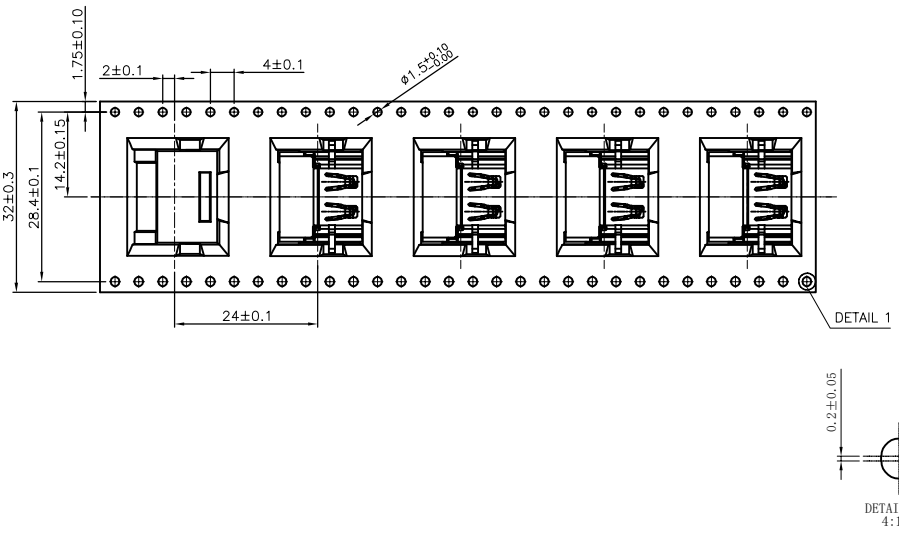
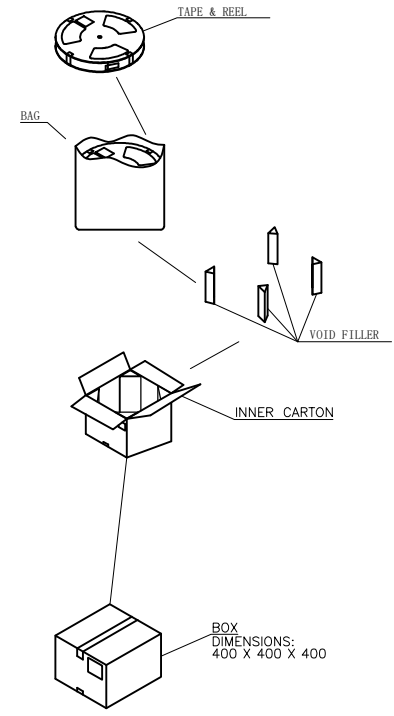
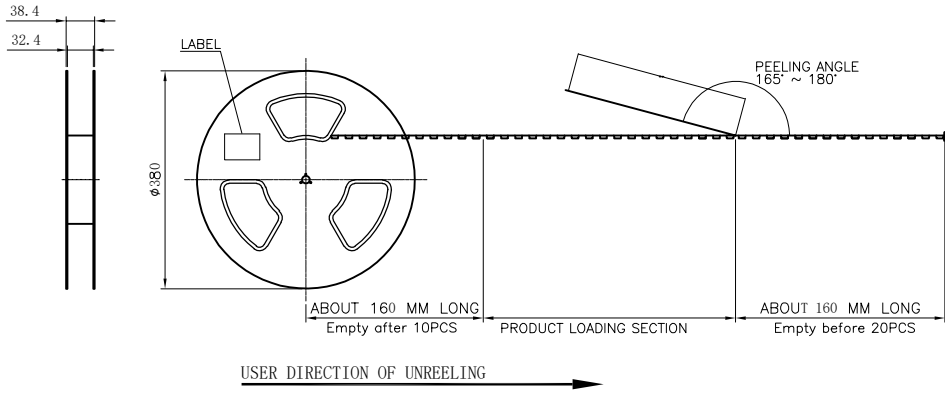

NOTE:

1. MATERIAL:  
 BOX: FIBREBOARD, CORRUGATED, DOUBLE WALL  
 TAPE: POLYSTYRENES, HEAT-RESISTANT TEMPERATURE: 120°C, Transparent COLOR.  
 REEL: POLYSTYRENES, HEAT-RESISTANT TEMPERATURE: 70°C, BLUE COLOR.  
 BAG: POLYETHYLENE, HEAT-RESISTANT TEMPERATURE: 100°C.
2. PEELING STRENGTH: 0.1 ~ 1.3 N (10 ~ 130 GRAMS)
3. PEELING SPEED: 300 mm/min.
4. EACH BAG SHALL BE INCLUDED DESICCANT.

500	10	5000	-- KG	-- KG
PCS/ REEL	REELS/ CARTON	QUANTITY	GROSS WEIGHT	NET WEIGHT

**Bestcreate Technology Limited**

TOLERANCES UNLESS OTHERWISE SPECIFIED:			
X.	± 0.50	X.*	± 3*
.X	± 0.30	.X.*	± 2*
.XX	± 0.20	.XX.*	± 1*

Tel/Whatsapp: 0086-13712299763  
 Skype: belle.wu3340

DESIGN:	I. L	DATE:	2017. 3. 1
CHECKED:	C. W	DATE:	2017. 3. 1
APPROVED:	C. W	DATE:	2017. 3. 1

TITLE: HDMI A TYPE 19PIN H=6.70 CH=1.95MM, REC RVS DIP TYPE		
MATERILA:	PART NO: HD01-AFXX5R-024	SIZE: A4
FINSH:	DWG NO: HD01-AFXX5R-024	

REV: A	UNIT: mm	SCALE: 1=1	QUALITY SYMBOLS
--------	----------	------------	-----------------