

RoHS Compliant

REVISIONS

REV.	DESCRIPTION	DATE	DESIGN

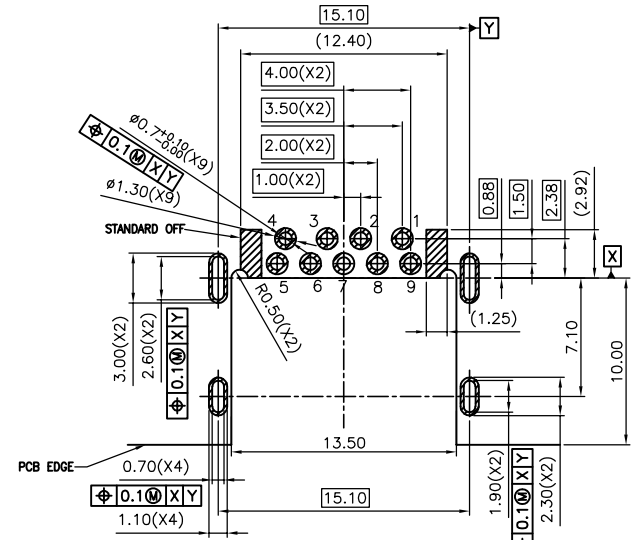
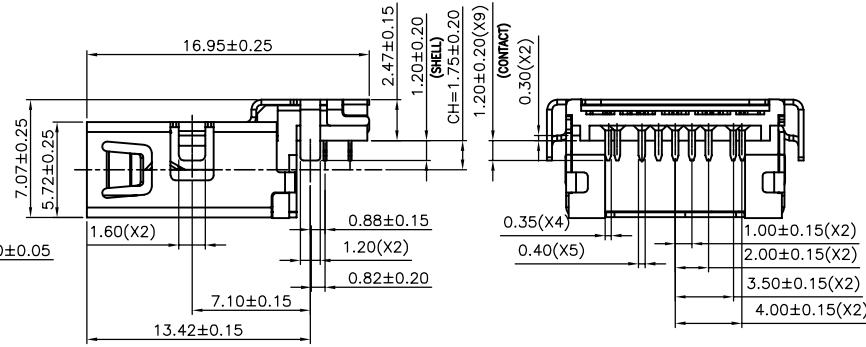
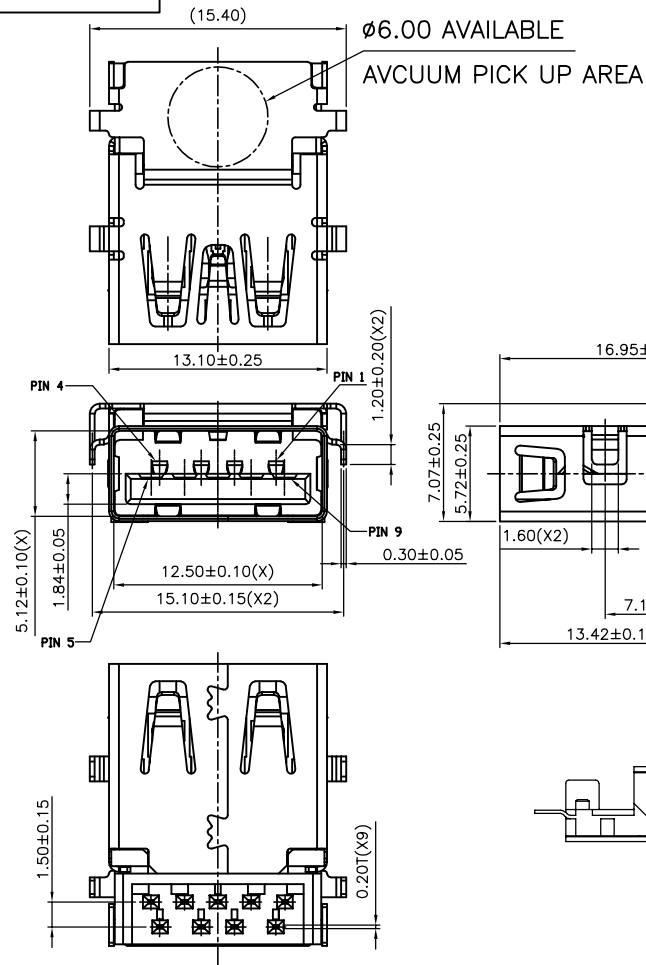

TOLERANCE: ±0.05, THICKNESS: 1.2mm  
RECOMMENDED PCB LAYOUT  
(TOP VIEW)

- NOTE:
- MATERIAL:
    - INSULATOR:LCP UL 94 V-0;BLUE/BLACK
    - CONTACT:C5191(T=0.20mm)
    - SHELL:SUS201(T=0.30mm)
  - ELECTRICAL CHARACTERISTICS:
    - Current Rating:1.5
    - Insulation Resistance:100MΩ Min
    - Contact Resistance:30mΩ Max
    - Dielectric Withstanding Voltage:500V AC
    - OPERATING TEMPERATURE:-40°C ~ 85°C
  - MECHANICAL CHARACTERISTICS:
    - MATING FORCE:35 N Max
    - UNMATED FORCE:10 N Min INITIAL; 8 N Min AFTER TEST
    - DURABILITY:5,000 CYCLES

PART NO. INFORMATION

**U03-A F X A X X -5012**

- PORT TYPE: A: TYPE A
- GENDER: F: FEMALE, M: MALE
- CONTACT PLATED: 1: GOLD FLASH, 2: GOLD 3U'', 3: GOLD 5U'', 4: GOLD 10U'', 5: GOLD 15U'', 6: GOLD 30U''
- PACKAGE: T: TRAY, R:TAPE REEL
- HOUSING COLOR: 2: WHITE, 5: BLACK, 9: BLUE
- HOUSING MATERIAL: A: LCP, B: PBT, C: PA9T, D: PA6T, E: PA46, F: PA66

Pin #	SIGNAL NAME	DESCRIPTION	MATING SEQUENCE
1	VBUS	POWER	SECOND
2	D-	USB 2.0 DIFFERENTIAL PAIR	THIRD
3	D+	DIFFERENTIAL PAIR	THIRD
4	GND	GROUND FOR POWER RETURN	SECOND
5	StdA_SSRx-	SUPERSPEED RECEIVER DIFFERENTIAL PAIR	LAST
6	StdA_SSRx+	DIFFERENTIAL PAIR	LAST
7	GND_DRAIN	GROUND FOR SIGNAL RETURN	SECOND
8	StdA_SSTx-	SUPERSPEED TRANSMITTER DIFFERENTIAL PAIR	LAST
9	StdA_SSTx+	DIFFERENTIAL PAIR	LAST
Shell	Shield	CONNECTOR METAL SHELL	FRIST

**Bestcreate Technology Limited**

TOLERANCES UNLESS OTHERWISE SPECIFIED:

X.	± 0.30	X.*	± 3*
.X	± 0.20	.X.*	± 2*
.XX	± 0.15	.XX.*	± 1*

DESIGN: I.L DATE: 2017.3.1

CHECKED: C.W DATE: 2017.3.1

APPROVED: C.W DATE: 2017.3.1

TITLE: USB 3.0 AF 板下沉板 CL-1.75  
L=16.95mm DIP YTYPE

MATERIAL: PART NO: U03-AFXAXX-5012 SIZE: A4

FINISH: DWG NO: U03-AFXAXX-5012 SHEET: 1 OF 2

Website: www.bsc-elec.com  
E-mail: bestcreate@bsc-elec.com

REV: A UNIT mm SCALE 1=1 QUALITY SYMBOLS

RoHS Compliant

REVISIONS			
REV.	DESCRIPTION	DATE	DESIGN

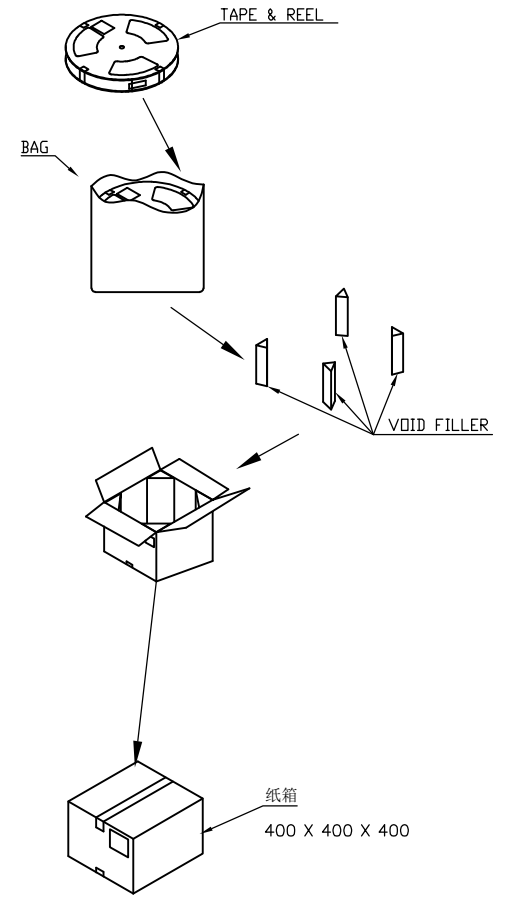
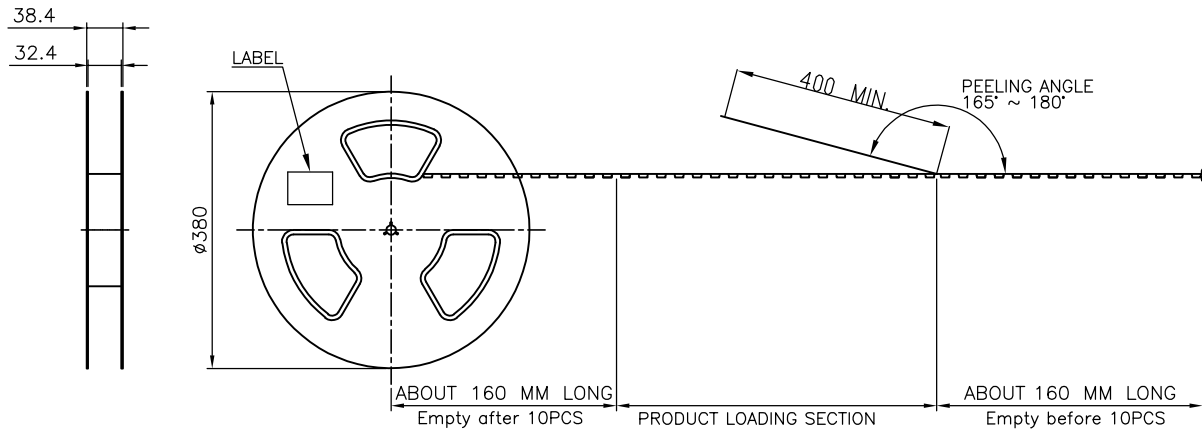

USER DIRECTION OF UNREELING →

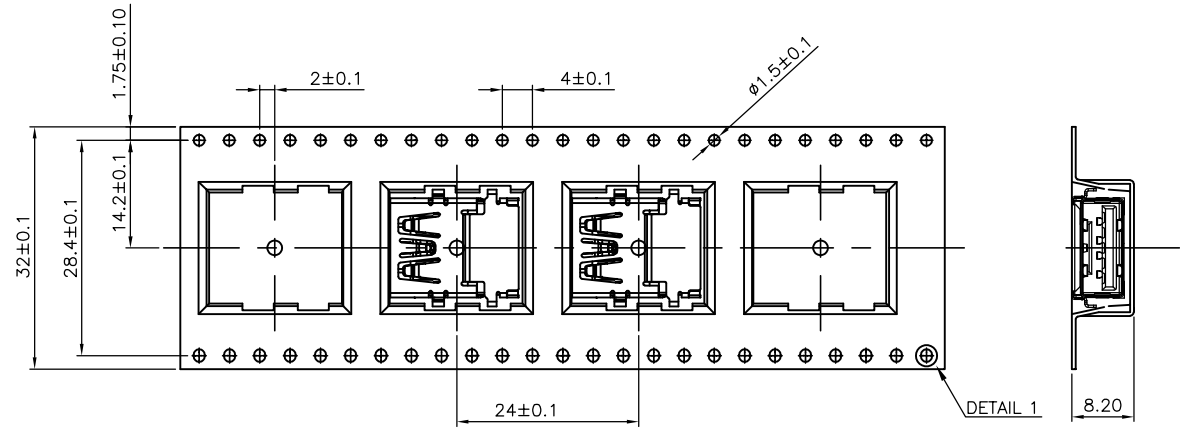

NOTE:

- MATERIAL:  
 BOX: FIBREBOARD, CORRUGATED, DOUBLE WALL  
 TAPE: POLYSTYRENES, HEAT-RESISTANT TEMPERATURE: 120°C, Transparent COLOR.  
 REEL: POLYSTYRENES, HEAT-RESISTANT TEMPERATURE: 70°C, BLUE COLOR.  
 BAG: POLYETHYLENE, HEAT-RESISTANT TEMPERATURE: 100°C.
- PEELING STRENGTH: 0.1 ~ 1.3 N (10 ~ 130 GRAMS)
- PEELING SPEED: 300 mm/min.
- EACH BAG SHALL BE INCLUDED DESICCANT.

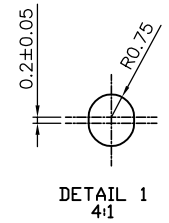

500	10	5000 PCS	-- KG	-- KG
PCS/ REEL	REELS/ CARTON	QUANTITY	GROSS WEIGHT	NET WEIGHT

**Bestcreate Technology Limited**

TOLERANCES UNLESS OTHERWISE SPECIFIED:

X.	± 0.30	X.*	± 3*
.X	± 0.20	.X*	± 2*
.XX	± 0.15	.XX*	± 1*

Website: [www.bsc-elec.com](http://www.bsc-elec.com)  
 E-mail: [bestcreate@bsc-elec.com](mailto:bestcreate@bsc-elec.com)

DESIGN: I.L  
 DATE: 2017.3.1  
 CHECKED: C.W  
 DATE: 2017.3.1  
 APPROVED: C.W  
 DATE: 2017.3.1

TITLE: USB 3.0 AF 板下沉板CL-1.75  
 L=16.95mm DIP YTYPE  
 MATERILA: PART NO: U03-AFXAXX-5012  
 FINSH: DWG NO: U03-AFXAXX-5012  
 SIZE: A4  
 SHEET: 2 OF 2

REV: A	UNIT mm	SCALE 1=1	QUALITY SYMBOLS
--------	---------	-----------	-----------------