

RoHS Compliant

REVISIONS			
REV.	DESCRIPTION	DATE	DESIGN

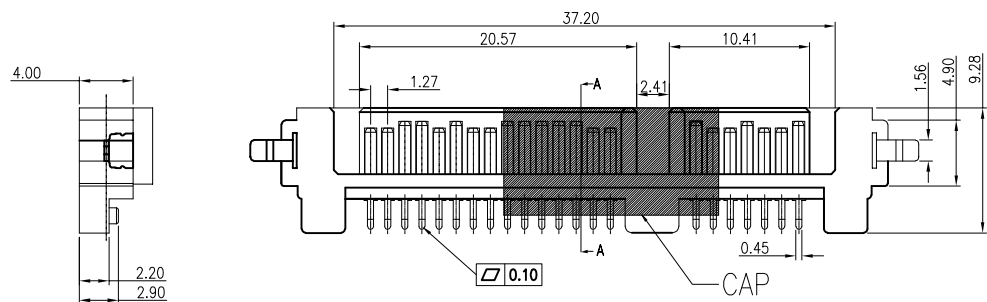
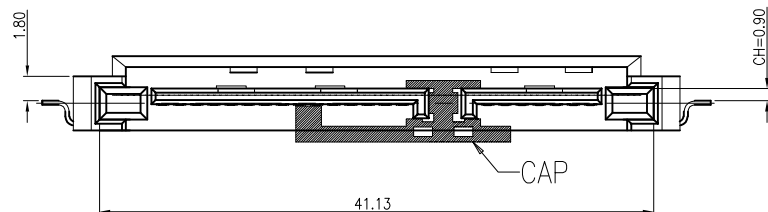
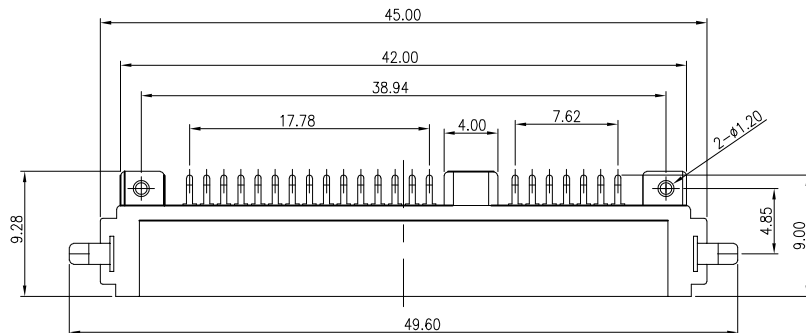

SPECIFICATION:
 1.MATERIAL:
 HOUSING: LCP E130I 30% G/F UL 94V-0
 COLOR:BLACK
 CONTACT: BRASS C2680 H,T=0.25mm
 PEG: BRASS C2680R H,T=0.30mm
 2.FINISH:
 CONTACT:11U" GOLD/TIN PLATING ON CONTACT AREA
 80u" MIN. TIN-LEAD PLATING ON SOLDERTAILS
 50u" MIN.NICKEL UNDERPLATING OVER ALL
 PEG:100u" MIN. TIN-LEAD PLATING ON SOLDERTAILS
 50u" MIN.NICKEL UNDERPLATING OVER ALL

PART NO. INFORMATION

S715 - M X A 5 T -009

GENDER
 F: FEMALE M: MALE

PACKAGE
 T: TRAY
 R:TAPE REEL

HOUSING COLOR
 5: BLACK

HOUSING MATERIAL A: LCP

CONTACT PLATED
 1: GOLD FLASH/TIN
 2: 15U" GOLD/TIN
 3: 30U" GOLD/TIN

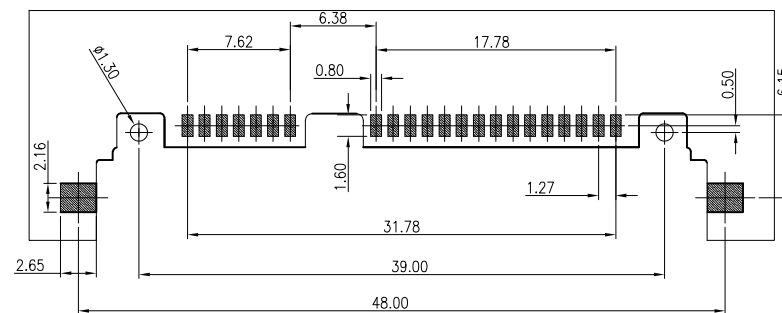

PCB LAYOUT

Bestcreate Technology Limited

TOLERANCES UNLESS OTHERWISE SPECIFIED:

X.	± 0.35	X.'	± 3'
.X	± 0.25	.X'	± 2'
.XX	± 0.15	.XX'	± 1'

Website: www.bsc-elec.com
 E-mail: bestcreate@bsc-elec.com

DESIGN: I. L DATE: 2017. 3. 1
 CHECKED: C. W DATE: 2017. 3. 1
 APPROVED: C. W DATE: 2017. 3. 1

TITLE: SATA 7+15P MALE MID MOUNT SMT,CH=0.9MM

MATERILA:	PART NO: S715-MXA5T-009	SIZE: A4
FINSH:	DWG NO: S715-MXA5T-009	SHEET: 1 OF 2

REV: A UNIT mm SCALE 1=1 QUALITY SYMBOLS

