

RoHS Compliant

REVISIONS			
REV.	DESCRIPTION	DATE	DESIGN

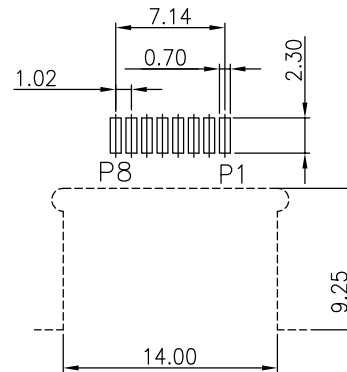
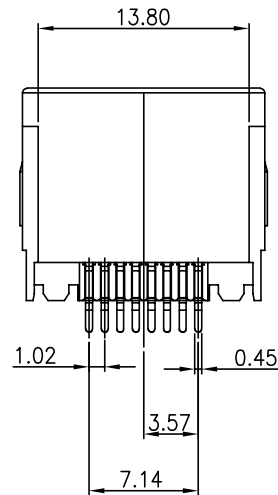
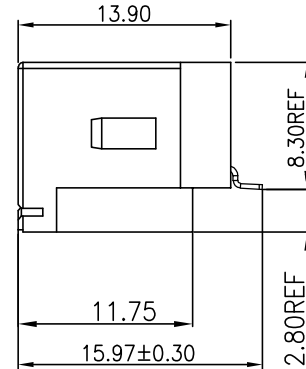
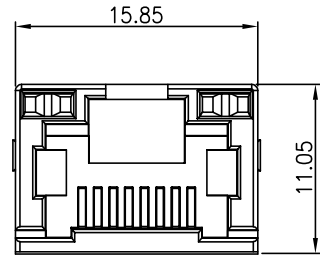

PCB LAYOUT
TOL: ±0.05

NOTES

MATERIAL

- 1. HOUSING MATERIAL : THERMO PLASTICS UL94V-0.
- 2. CONTACT MATERIAL : PHOSPHOR BRONZE T=0.3.
- 3. PLATING : GOLD PLATING ON CONTACT AREA TIN PLATED ON SOLDER AREA, NICKEL PLATED OVER ALL.

ELECTRICAL

- 1. VOLTAGE RATING : 125 VAC RMS.
- 2. CURRENT RATING : 1.5 AMP.
- 3. CONTACT RESISTANCE : 40 MILLIOHMS MAX.
- 4. INSULATION RESISTANCE : 500 MEGOHMS MIN @ 100V DC .
- 5. DIELECTRIC DIELECTRIC RESISTANCE : 500V DC RMS 50Hz. 1MIN.

MECHANICAL

- 1. DURRABILITY : 750 CYCLES MIN.
- 2. MATING/UNMATING FORC: 2.24 KG.F MAX.

ENVIRONMENTAL:

- 1. OPERATION : -40°C~+85°C.
- 2. STORAGE : -40°C~+85°C.

PART NO. INFORMATION

RJ01- X 5 X X - 099

CONTACT PLATED
1: G/F 2: AU 3U"
3: AU 6U"

PACKAGE
R: TAPE REEL
T: TRAY

HOUSING:
1: PBT BLACK

Bestcreate Technology Limited

TOLERANCES UNLESS OTHERWISE SPECIFIED:

.X	± 0.35	X.'	± 3'
.XX	± 0.25	.X'	± 2'
.XXX	± 0.15	.XX'	± 1'

Website: www.bsc-elec.com

Email: bestcreate@bsc-elec.com

DESIGN: I. L DATE: 2017. 3. 1

CHECKED: C. W DATE: 2017. 3. 1

APPROVED: C. W DATE: 2017. 3. 1

TITLE: MID-MOUNT 8.4MM RJ45 SMT CONNECTOR

MATERILA: FINISH: PART NO: RJ01-X5XX-099 SIZE: A4

DWG NO: RJ01-X5XX-099

REV:	UNIT	SCALE	QUALITY SYMBOLS
A	mm	1=1	