

RoHS Compliant

REVISIONS			
REV.	DESCRIPTION	DATE	DESIGN

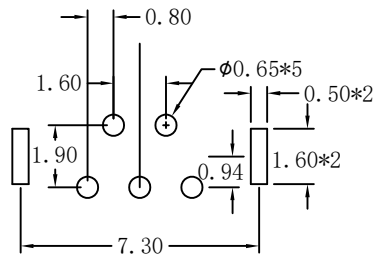

RECOMMENDED PCB LAYOUT

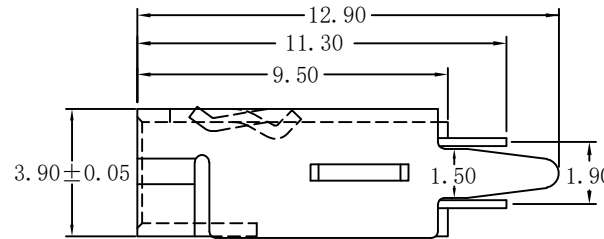
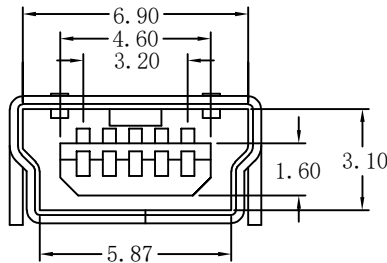
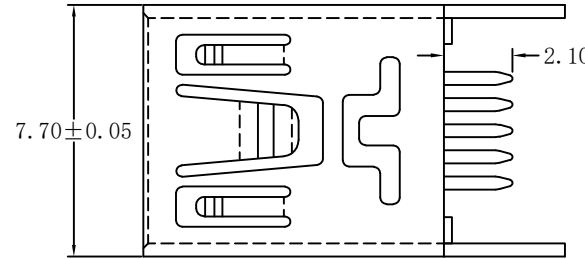
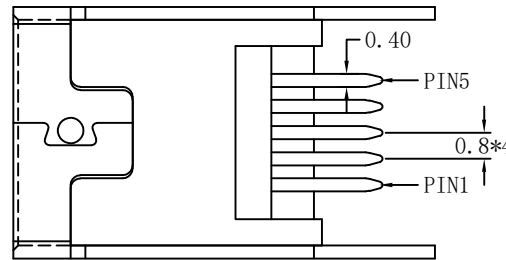

规格说明: Specifications:

电气特性: Electrical:

- 额定电流: Current Rating
1.0A/contact terminal
- 额定电压: Voltage Rating
30V DC
- 接触阻抗: Contact Resistance
50 milliohms MAX
- 耐电压: Dielectric Withstanding Voltage:
300 V AC AT Sea Level
- 绝缘阻抗: Insulation Resistance:
100MEGA ohms MIN

原材料: Raw material:

- 塑胶: Plastic cement:
Hing Temperature Thermoplastics,
UL 94V-0 LCP Black
- 端子: Contact: Copper Alloy C5191/C2680
- 外壳: Shell: Copper Alloy C2680

电镀: Electroplate:

- 端子: Contact: Plated Gold in Mating Area;
Tin On Solder Tails
- 外壳: Shell:
Nickel Plating

PART NO. INFORMATION

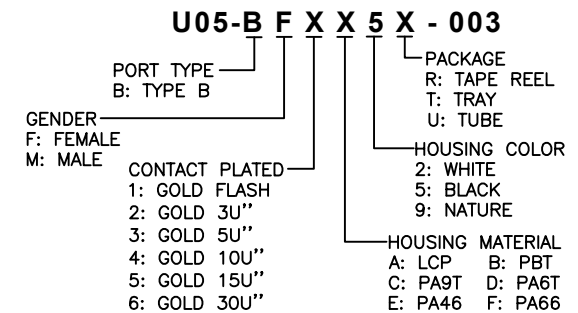

Bestcreate Technology Limited

TOLERANCES UNLESS OTHERWISE SPECIFIED:

X.	±	0.50	X.'	±	3'
.X	±	0.25	.X'	±	2'
.XX	±	0.15	.XX'	±	1'

Website: www.bsc-elec.com

Email: bestcreate@bsc-elec.com

DESIGN:

DATE:

I. L

2017. 3. 1

CHECKED:

DATE:

C. W

2017. 3. 1

APPROVED:

DATE:

C. W

2017. 3. 1

TITLE:

MINI USB 5P BF 180°
DIP(直尖脚)

MATERILA:

PART NO:

U05-BFXX5X-003

SIZE: A4

FINSH:

DWG NO:

U05-BFXX5X-003

REV: A

UNIT mm

SCALE 1=1

QUALITY SYMBOLS



1

2

3

4

5

6

7

8