

RoHS Compliant

REVISIONS			
REV.	DESCRIPTION	DATE	DESIGN

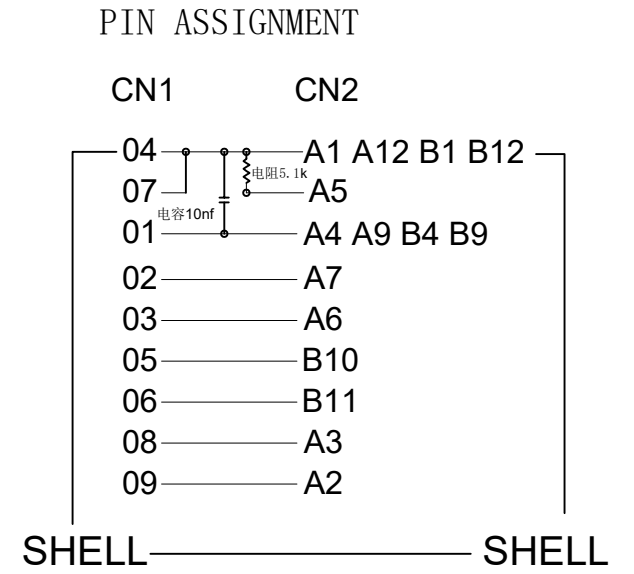
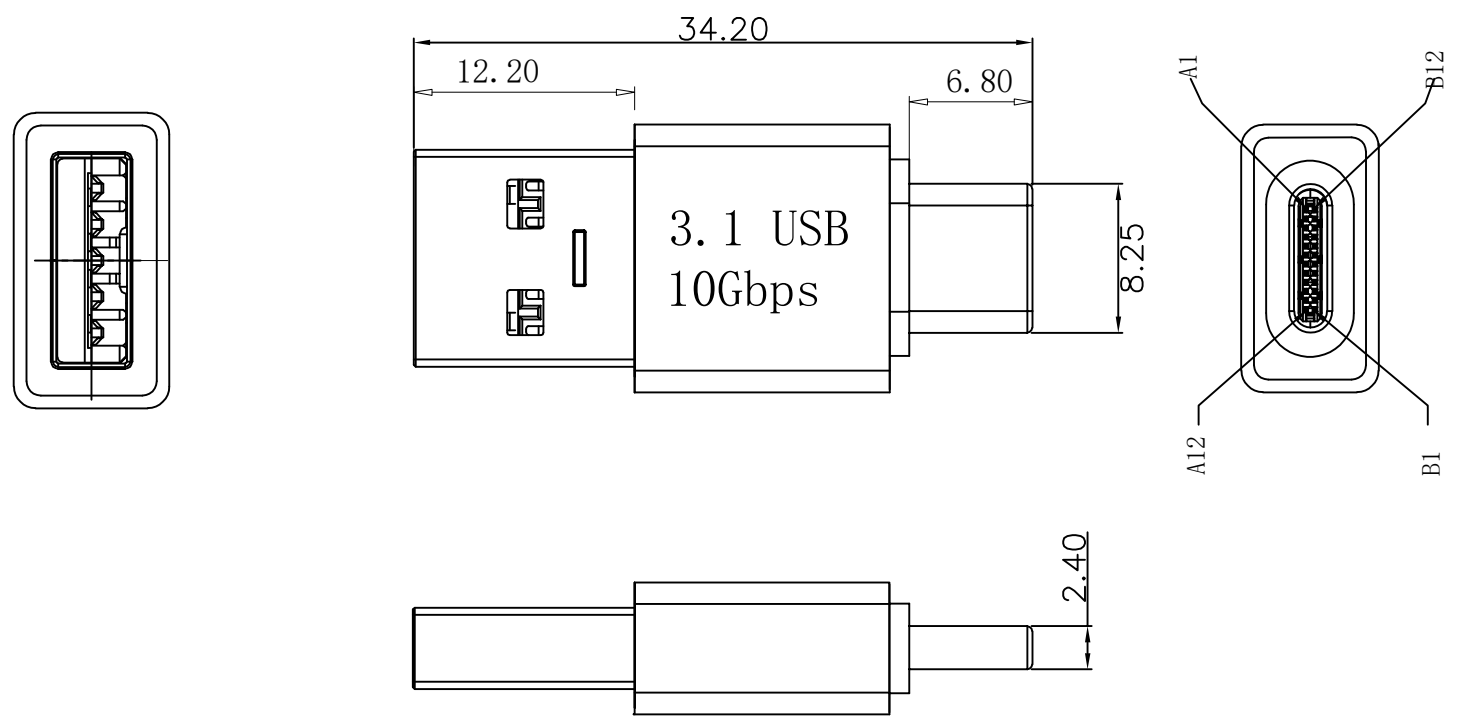

- NOTE:
- ELECTRICAL CHARACTERISTICS;
 - CONTACT RESISTANCE: 80mΩ Max
 - CONTACT CURRENT RATING: 1.5 A
 - DIELECTRIC WITHSTANDING VOLTAGE: 100 V R. M. S.
 - INSULATION RESISTANCE 100 MEGOHMS Min
 - OPERATING TEMPERATURE: -25° C ~ 75° C
 - MECHANICAL CHARACTERISTICS:
 - MATING FORCE: USB CM 5~20N & USB3.0 AF 35N Max.
 - UNMATED FORCE: USB CM 8~20N & USB3.0 AF 10N Min.
 - PLATING
 - TERMINAL CONTACT: (SEE TAB) GOLD PLATING ALL OVER 50u"MIN NICKEL
 - SHELL: 50u"MIN. NICEL ALL OVER

Color
White
Black

3	USB AF		USB3.0 AF Plastic cover 28*16.24*8.52mm,white&Black	1PCS
2	TYPE C		PVC 45P,COLOR: WHITE&Black	0.005KG
1	PCBA		USB3.0 AM TO TYPE CF R: 5.1k C: 10nF,nickel plated	1PCS
Item	Name	Part Number	Description	Q'TY

Bestcreate Technology Limited

TOLERANCES UNLESS OTHERWISE SPECIFIED:		DESIGN:	DATE:	TITLE:	
X.	± 0.50	I.L	2017.3.1	USB3.1 CM TO USB3.0 AM ADAPTER METAL CASE, L=34.2MM	
.X	± 0.30	CHECKED:	DATE:	MATERILA:	PART NO:
.XX	± 0.10	C.W	2017.3.1		AD31CMAM-049
Website: www.bsc-elec.com		APPROVED:	DATE:	FINSH:	DWG NO:
Email: bestcreate@bsc-elec.com		C.W	2017.3.1		AD31CMAM-049

REV: A	UNIT mm	SCALE 1=1	QUALITY SYMBOLS
--------	---------	-----------	-----------------

RoHS Compliant

REVISIONS			
REV.	DESCRIPTION	DATE	DESIGN

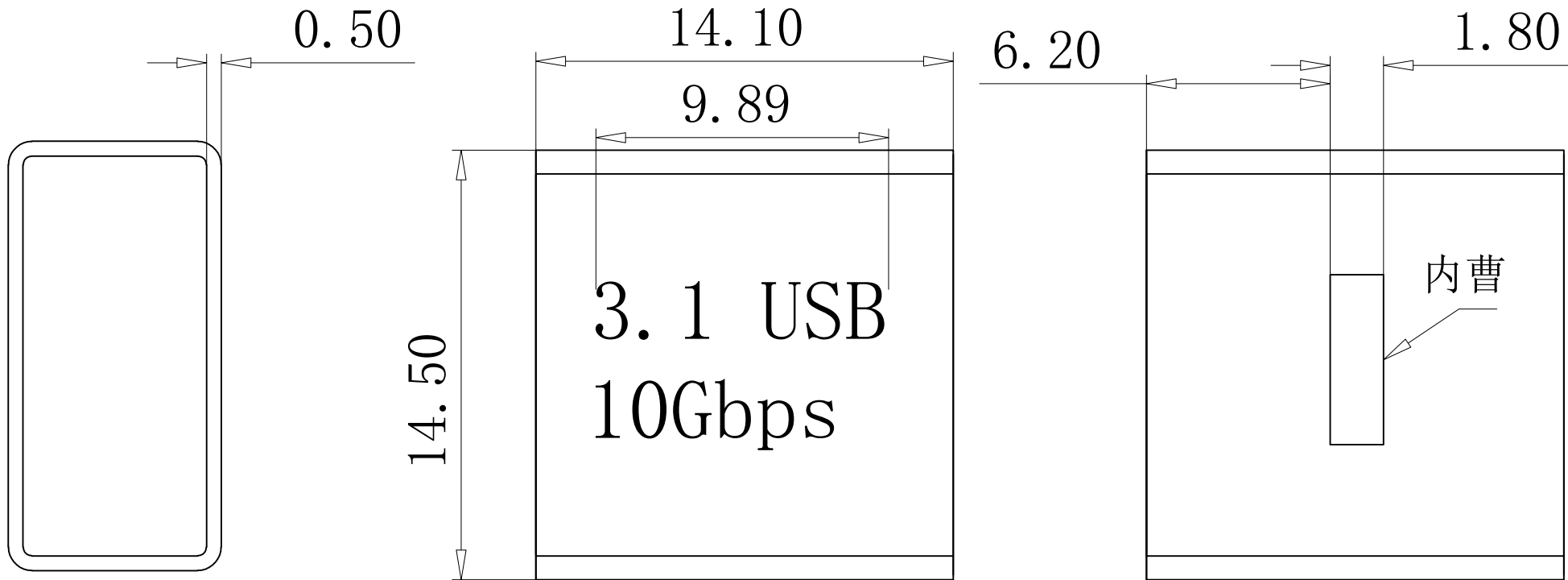

3.1 USB
10Gbps

内曹

Material: Aluminum Alloy
Color: Black

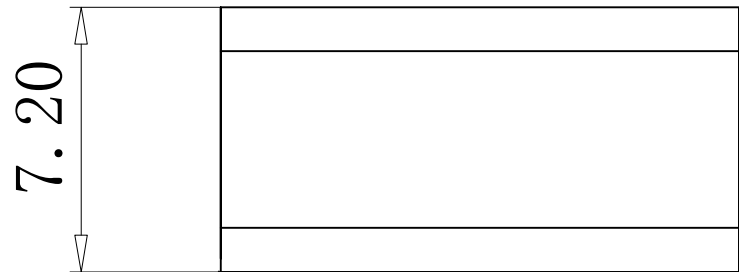

Bestcreate Technology Limited

TOLERANCES UNLESS OTHERWISE SPECIFIED:

X.	± 0.50	X'	± 5'
.X	± 0.30	.X'	± 2'
.XX	± 0.10	.XX'	± 1'

DESIGN:	DATE:
I.L	2017.3.1
CHECKED:	DATE:
C.W	2017.3.1
APPROVED:	DATE:
C.W	2017.3.1

TITLE: USB3.1 CM TO USB3.0 AM ADAPTER METAL CASE, L=34.2MM		
MATERILA:	PART NO: AD31CMAM-049	SIZE: A4
FINSH:	DWG NO: AD31CMAM-049	

REV: A	UNIT mm	SCALE 1=1	QUALITY SYMBOLS
-----------	------------	--------------	---------------------

Website:www.bsc-elec.com
Email:bestcreate@bsc-elec.com