

RoHS Compliant

REVISIONS			
REV.	DESCRIPTION	DATE	DESIGN

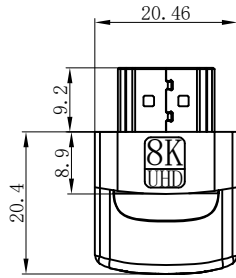

HDMI WIRING TABLE

P1	P2
1	1
3	3
2	2
4	4
6	6
5	5
7	7
9	9
8	8
10	10
12	12
11	11
14	14
19	19
17	17
13	13
15	15
16	16
18	18
外壳	外壳

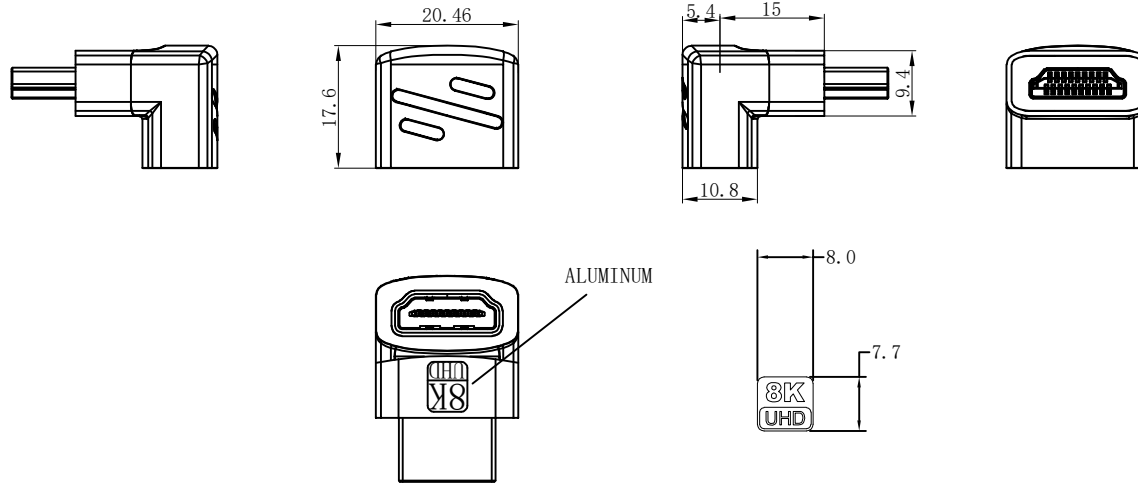

TEST CONDITION:

- a. 100% SHORT CIRCUIT/OPEN CIRCUIT TEST.
- b. DC:300V AC:200V INSULATION RESISTANCE:10MΩ
- c. CONDUCTOR RESISTANCE : ≤5Ω
- d. 8K\*4K 60HZ VIDEO AND AUDIO TEST.

ITEM	MATERIAL	SPECIFICATION	UNIT	QTY
7	PACKAGE	SELF SEAL ZIPPER PE BAG	pcs	1
6	PVC MATERIAL	45P CAL65 N18P ENVIRONMENTAL MATERIAL	g	6
5	PE MATERIAL	PE LOW DENSITYTYPE INTERNAL MOLD MATERIAL	g	3
4	ALUMINUM SHELL	BLACK ALUMINUM SHELL9.4mm*8.9mm*20.46mm NETC LOGO	pcs	2
3	PCBA	4 LAYER PCBA	pcs	1
2	CONNECTOR	HDMI AM SPCC SHELL WITH GOLD PLATING, 3U' ON CONTACT, STRADDLE MOUNT	PCS	1
1	CONNECTOR	HDMI AF SPCC SHELL WITH GOLD PLATING, 3U' ON CONTACT, STRADDLE MOUNT	PCS	1

**Bestcreate Technology Limited**

TOLERANCES UNLESS OTHERWISE SPECIFIED:

X.	± 0.50	X.*	± 5*
.X	± 0.30	.X.*	± 2*
.XX	± 0.10	.XX.*	± 1*

DESIGN: I. L DATE: 2017.3.1

CHECKED: C. W DATE: 2017.3.1

APPROVED: C. W DATE: 2017.3.1

TITLE: HDMI AM TO AF 8K ALUMINUM SHELL ADAPTER 270°

MATERILA: FINSH: PART NO: HDAMAF8K-005 SIZE: A4

DWG NO: HDAMAF8K-005

REV: A UNIT mm SCALE 1=1 QUALITY SYMBOLS

Website:www.bsc-elec.com Email:bestcreate@bsc-elec.com