

RoHS Compliant

REVISIONS			
REV.	DESCRIPTION	DATE	DESIGN

A

B

C

A

B

C

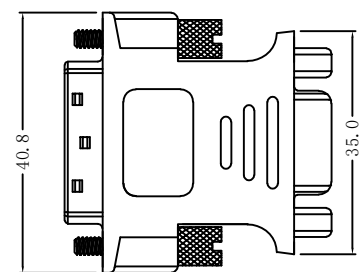

CN1

CN2

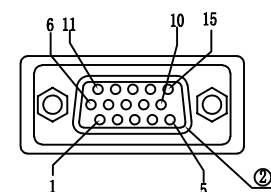
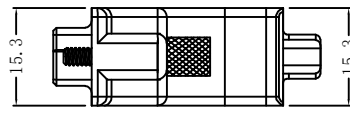
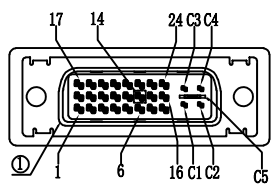

接点表

CN1	CN2
C1	1
C2	2
C3	3
15	5
	10
C5	6
	7
	8
14	
16	9
7	12
C4	13
8	14
6	15
SHELL	SHELL

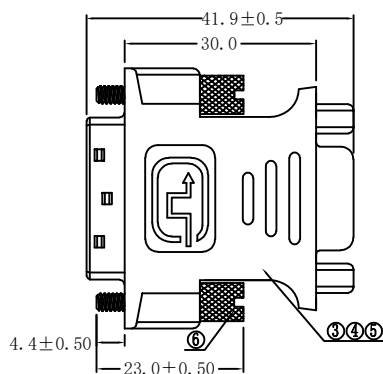

注:

- 100%短/断路&错线测试条件.
- 导通阻抗 $\leq 3\Omega$ , 绝缘阻抗 $\geq 10M\Omega$ . 高压测试, DC 300V/10mS.
- 产品采用PCB板连接.
- 成品包装: 1个外箱装3个内箱, 每个内箱装100pcs, 外箱侧面右上角需贴上物料标签.
- 所用材质须符合ROHS要求.

6	螺丝	铁头螺丝 镀金&镀镍 长:23MM	5.18.05	2PCS
5	外模	PVC胶料 45P 黑色	5.09.02-1	11.7G
4	内模	PVC胶料 45P 黑色	5.09.02-1	5.1G
3	内连接	PCB板 T=1.6MM	5.12.035	1PCS
2	连接器	VGA 15P F 前脚螺丝 铁壳镀金&镀镍 PIN针镀金G/F 蓝胶	镀金5.06.01-5 镀镍5.06.02-5	1PCS
1	连接器	DVI (24+5) M 铁壳镀金&镀镍 PIN针镀金G/F 黑胶	镀金5.05.16-1 镀镍5.05.17-1	1PCS
序号	名称	材料	物料编号	用量

**Bestcreate Technology Limited**

TOLERANCES UNLESS OTHERWISE SPECIFIED:			
X.	±	0.50	X.* ± 5'
.X	±	0.30	.X* ± 2'
.XX	±	0.10	.XX* ± 1'
Website:www.bsc-elec.com			
Email:bestcreate@bsc-elec.com			

DESIGN:	DATE:
I. L	2017. 3. 1
CHECKED:	DATE:
C. W	2017. 3. 1
APPROVED:	DATE:
C. W	2017. 3. 1

TITLE:		
DVI24+5 MALE TO VGA 15P FEMALE ADAPTER		
MATERILA:	PART NO:	SIZE:
	DVI245TOVGA15PM-004	A4
FINSH:	DWG NO:	
	DVI245TOVGA15PM-004	

REV:	UNIT	SCALE	QUALITY SYMBOLS
A	mm	1=1	