

RoHS Compliant

REVISIONS			
REV.	DESCRIPTION	DATE	DESIGN

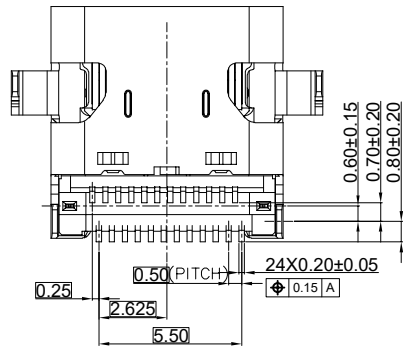
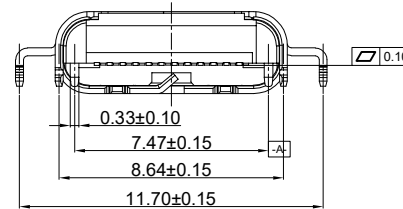
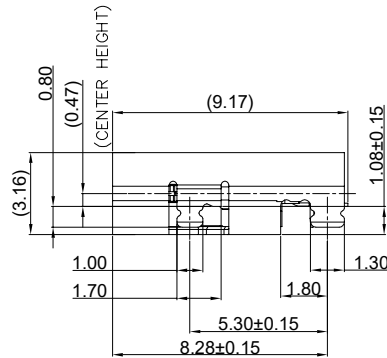
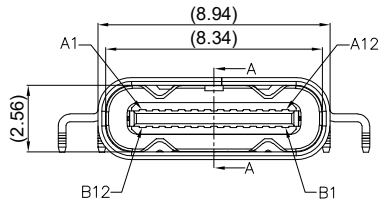
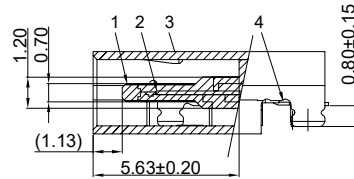
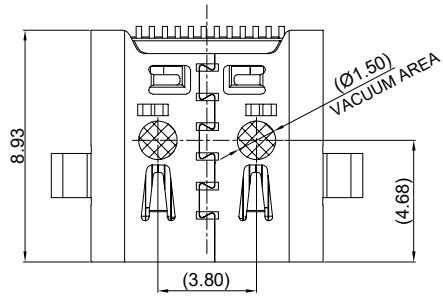

NOTE/注释:

1. SPECIFICATION/规格:
 - 1.1 Rated current (额定电流): 5.0 A
 - 1.2 Voltage rating (额定电压): 5V AC
 - 1.3 Contact Resistance (接触阻抗): 40 m Ω Max.
 - 1.4 Insulation Resistance (绝缘阻抗): 100MΩ Min.
 - 1.5 Withstanding voltage (耐电压): 100 VAC/minute
 - 1.6 Mating force (插入力): 5~20N .
 - 1.7 Unmating force (拔出力): 8~20N.
 - 1.8 Durability Cycle(寿命循环): 10,000 cycle
 - 1.9 Operating temperature (工作温度): -40°~+85°

PART NO. INFORMATION

U06-40 C F X X 5 R - 006-V1

- PORT TYPE
C: TYPE C
- GENDER
F: FEMALE
M: MALE
- CONTACT PLATED
1: GOLD FLASH
2: GOLD 3U"
3: GOLD 5U"
4: GOLD 10U"
5: GOLD 15U"
6: GOLD 30U"
- PACKAGE
R: TAPE REEL
- HOUSING COLOR
2: WHITE
5: BLACK
9: NATURE
- HOUSING MATERIAL
A: LCP B: PBT
C: PA9T D: PA6T
E: PA46 F: PA66

ITEM	DESCRIPTION	QTY	MATERIAL	FINISH	REMARK
4	TERMINAL	24	C18140	MATING SIDE-SEE PART NO; SOLDER TAIL:Gold FLASH, 50μ NICKEL OVERALL.	T=0.12
3	SHELL	1	SUS304	NICKEL PLATING	T=0.30
2	MID PLATE	1	SUS301	NICKEL PLATING	T=0.15
1	MAIN HOUSING	1	PA9T HF 30%玻纤, UL94 V-0, 黑色		BLACK UL94V-0
BILL OF MATERIAL					

Bestcreate Technology Limited

TOLERANCES UNLESS OTHERWISE SPECIFIED:

.X	± 0.30	.X'	± 5'
.XX	± 0.20	.X''	± 2'
.XXX	± 0.10	.X'''	± 1'

Website: www.bsc-elec.com
Email: bestcreate@bsc-elec.com

DESIGN: I. L	DATE:	TITLE: USB4.0 TYPE C 24P FEMALE CONNECTOR DUAL SMT, MID MOUNT 1.1MM, L=9.17MM
CHECKED: C. W	DATE:	MATERILA: PART NO: U06-40CFXX5R-006-V1
APPROVED: C. W	DATE:	FINSH: DWG NO: U06-40CFXX5R-006-V1
		SIZE: A4 1 OF 3

REV: A UNIT: mm SCALE: 1=1 QUALITY SYMBOLS:

RoHS Compliant

REVISIONS			
REV.	DESCRIPTION	DATE	DESIGN

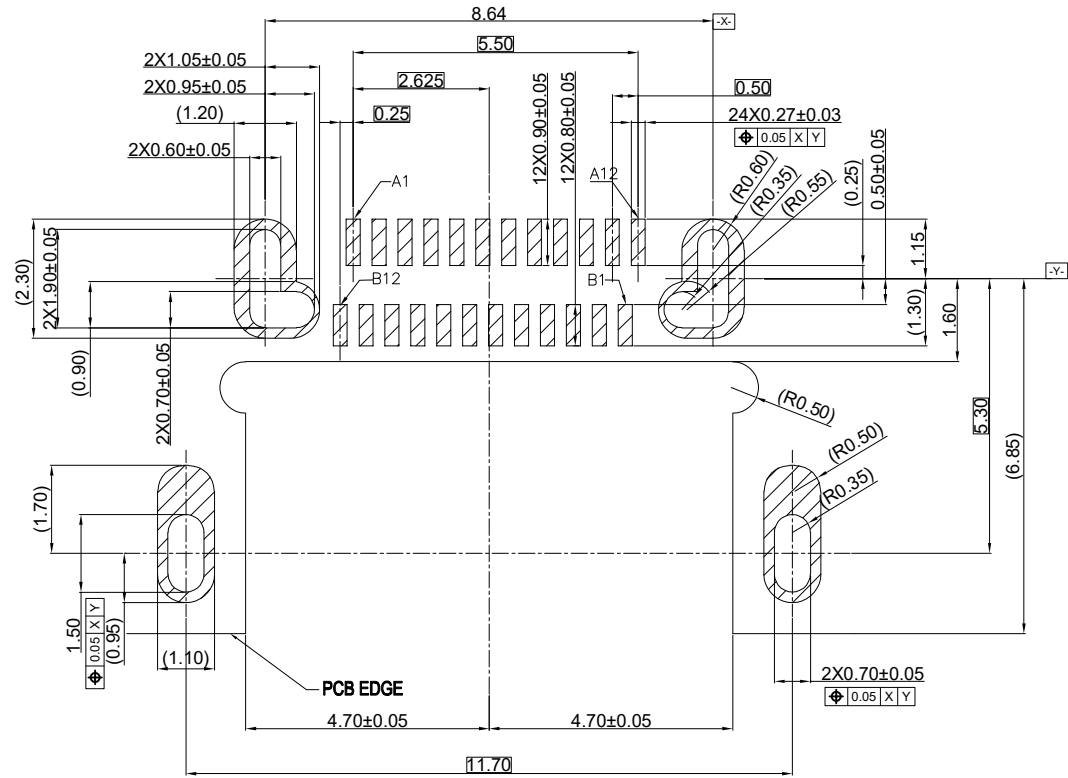

USB TYPE-C PIN ASSIGNMENTS

PIN NUMBER	SIGNAL NAME	PIN NUMBER	SIGNAL NAME
A1	GND	B12	GND
A2	SSTXp1	B11	SSRXp1
A3	SSTXn1	B10	SSRXn1
A4	VBUS	B9	VBUS
A5	CC1	B8	SBU2
A6	Dp1	B7	Dn2
A7	Dn1	B6	Dp2
A8	SBU1	B5	CC2
A9	VBUS	B4	VBUS
A10	SSRXn2	B3	SSTXn2
A11	SSRXp2	B2	SSTXp2
A12	GND	B1	GND

Bestcreate Technology Limited

TOLERANCES UNLESS OTHERWISE SPECIFIED:

.X	± 0.30	.X'	± 5°
.XX	± 0.20	.X''	± 2°
.XXX	± 0.10	.XX'	± 1°

Website: www.bsc-elec.com
Email: bestcreate@bsc-elec.com

DESIGN: I.L DATE:

CHECKED: C.W DATE:

APPROVED: C.W DATE:

TITLE: USB4.0 TYPE C 24P FEMALE CONNECTOR DUAL SMT, MID MOUNT 1.1MM, L=9.17MM

MATERIAL: PART NO: U06-40CFXX5R-006-V1 SIZE: A4

FINISH: DWG NO: U06-40CFXX5R-006-V1 2 OF 3

REV: A UNIT mm SCALE 1=1 QUALITY SYMBOLS

RoHS Compliant

REVISIONS			
REV.	DESCRIPTION	DATE	DESIGN

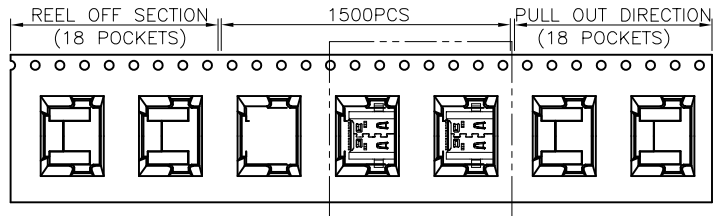

SEE DETAIL X

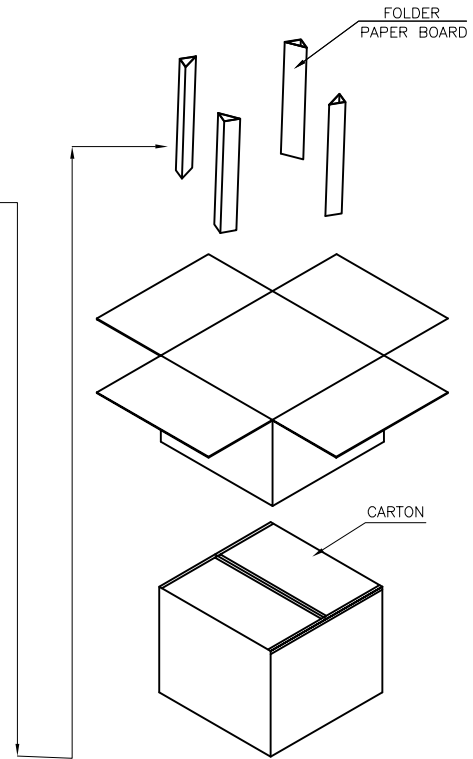
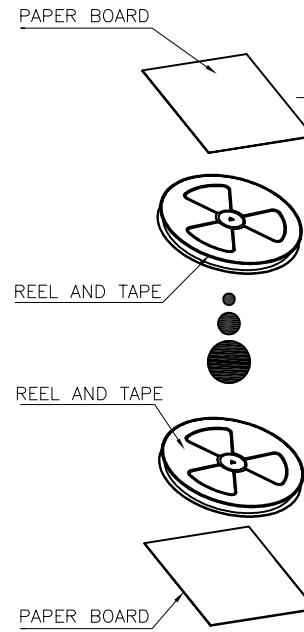
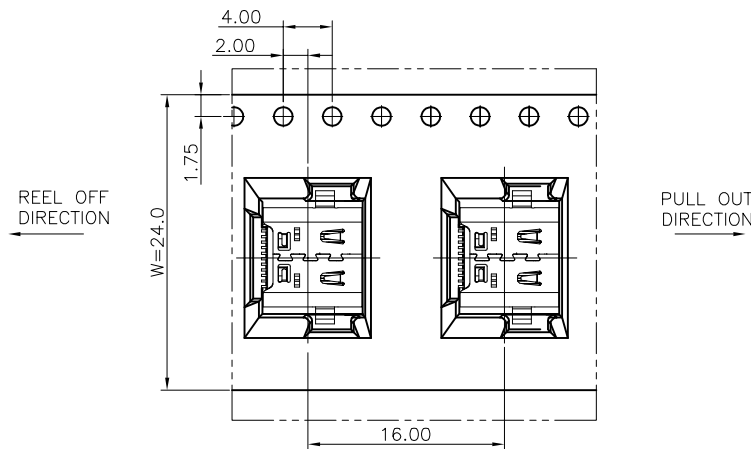
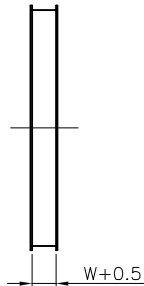
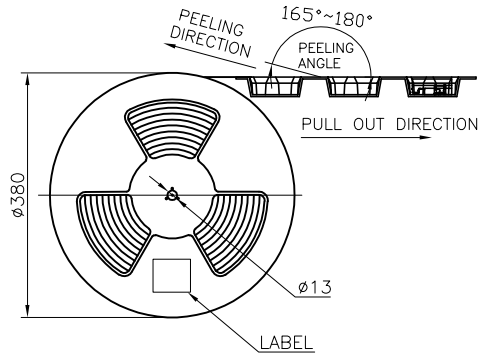

	REEL	CARTON
CONNECTOR (PCS)	1500	15000

Bestcreate Technology Limited

TOLERANCES UNLESS OTHERWISE SPECIFIED:

.X	± 0.30	X'	± 5'
.XX	± 0.20	.X'	± 2'
.XXX	± 0.10	.XX'	± 1'

DESIGN: I. L DATE:

CHECKED: C. W DATE:

APPROVED: C. W DATE:

TITLE: USB4.0 TYPE C 24P FEMALE CONNECTOR DUAL SMT, MID MOUNT 1.1MM, L=9.17MM

MATERIAL:	PART NO: U06-40CFXX5R-006-V1	SIZE: A4
FINISH:	DWG NO: U06-40CFXX5R-006-V1	3 OF 3

Website: www.bsc-elec.com
Email: bestcreate@bsc-elec.com

REV:	UNIT	SCALE	QUALITY SYMBOLS
A	mm	1=1	