

RoHS Compliant

REVISIONS			
REV.	DESCRIPTION	DATE	DESIGN

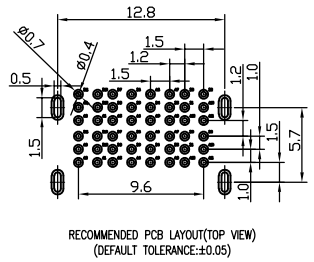

NOTE:
1. MATERIAL:
1.1 HOUSING: LCP, UL 94V-0, COLOR- BLUE (PANTONE 300C) OR BLACK
1.2 BOTTOM COVER: LCP, UL 94V-0, COLOR- BLUE (PANTONE 300C) OR BLACK
1.3 CONTACT: C7025(T=0.12mm);C2680(T=0.15mm)
1.4 SOCKET SHELL: SUS304-1/2H(T=0.3mm)
1.5 FRONT MIDDLE SHELL:SUS304-1/2H(T=0.25mm)
1.6 REAR SHELL:SUS304-1/2H(T=0.2mm)
1.7 MID PLATE:SUS301-1/2H(T=0.15mm)
1.8 PCB: FR4
2. ELECTRICAL CHARACTERISTICS:
2.1 CONTACT RESISTANCE: 30mΩ Max FOR INITIAL, 10mΩ CHANGE AFTER TEST, MEASURE AT 20mV, 100mA.
2.2 CONTACT CURRENT RATING: 5A FOR COLLECTIVELY POWER SUPPLY PIN(PIN1, A4, A9, A12, B1, B4, B9, B12); 1.25A FOR VCONN PIN; 0.25A FOR OTHER SIGNAL PIN.
2.3 DIELECTRIC WITHSTANDING VOLTAGE: 100V AC R.M.S.
2.4 INSULATION RESISTANCE 100MΩ Min
2.5 OPERATING TEMPERATURE: -40° C ~ 85° C
3. MECHANICAL CHARACTERISTICS:
3.1 MATING FORCE: 5~20 N.
3.2 UNMATED FORCE: 8~20N INITIAL TEST; 6~20N DURABILITY AFTER TEST
3.3 DURABILITY: 10,000 CYCLES
4. PLATING
4.1 TERMINAL CONTACT: 1μ" GOLD PLATING ON CONTACT AREA, ALL OVER 50μ" Min NICKEL AND 1μ" Min Matte GOLD ALL OVER 50μ" Min NICKEL ON SOLDER AREA
4.2 SHELL: 50μ" Min, NICKEL ALL OVER.
4.3 MID PLATE: CLEAN

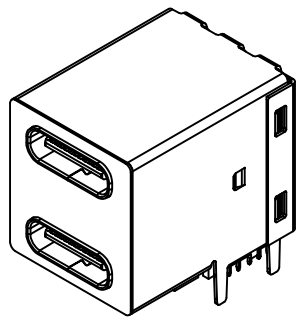
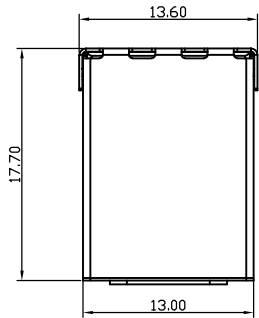
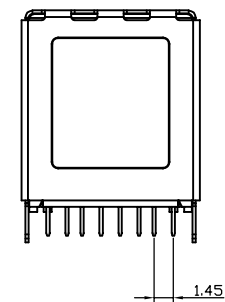
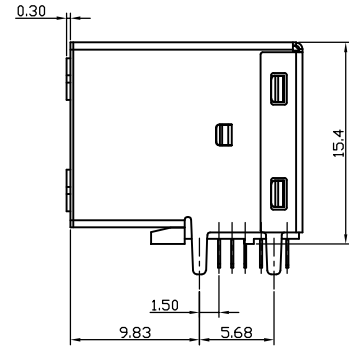
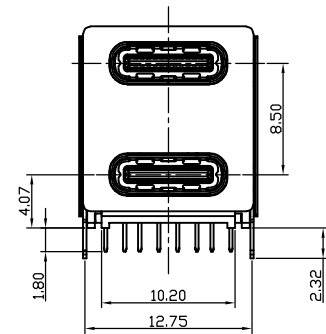

PIN	Signal Name	Description	PIN	Signal Name	Description
A1	GND	Ground return	B12	GND	Ground return
A2	SSTxp1	Positive half of first SuperSpeed TX differential pair	B11	SSRxp1	Positive half of first SuperSpeed RX differential pair
A3	SSTxm1	Negative half of first SuperSpeed TX differential pair	B10	SSRxm1	Negative half of first SuperSpeed RX differential pair
A4	Vbus	Bus Power	B9	Vbus	Bus Power
A5	CC1	Configuration Channel	B8	SRB2	Sideband Use (SRB)
A6	Dp1	Positive half of the USB 2.0 differential pair-Position 1	B7	Dm2	Negative half of the USB 2.0 differential pair-Position 2
A7	Dm1	Negative half of the USB 2.0 differential pair-Position 1	B6	Dp2	Positive half of the USB 2.0 differential pair-Position 2
A8	SRB1	Sideband Use (SRB)	B5	CC2	Configuration Channel
A9	Vbus	Bus Power	B4	Vbus	Bus Power
A10	SSRxq2	Negative half of second SuperSpeed RX differential pair	B3	SSTxq2	Negative half of second SuperSpeed TX differential pair
A11	SSRxp2	Positive half of second SuperSpeed RX differential pair	B2	SSTxp2	Positive half of second SuperSpeed TX differential pair
A12	GND	Ground return	B1	GND	Ground return

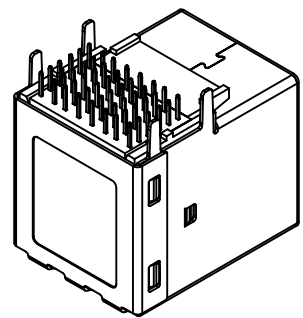
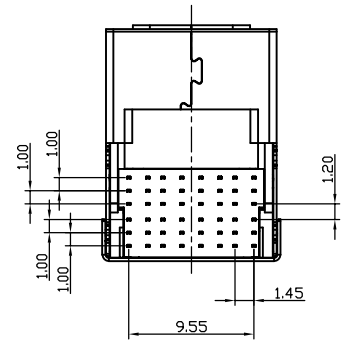

PART NO. INFORMATION
U06-DC F 2 X 5 T - 001

PORT TYPE
DC: DUAL TYPE C

GENDER
F: FEMALE
M: MALE

CONTACT PLATED
1: GOLD FLASH
2: GOLD 3U"
3: GOLD 5U"
4: GOLD 10U"
5: GOLD 15U"
6: GOLD 30U"

PACKAGE
T: TRAY

HOUSING COLOR
2: WHITE
5: BLACK
9: NATURE

HOUSING MATERIAL
A: LCP B: PBT
C: PA9T D: PA6T
E: PA46 F: PA66

Bestcreate Technology Limited

TOLERANCES UNLESS OTHERWISE SPECIFIED:
X. ± 0.50 X.* ± 3°
.X ± 0.30 .X.* ± 2°
.XX ± 0.20 .XX.* ± 1°

Website: www.bsc-elec.com
E-mail: bestcreate@bsc-elec.com

DESIGN: I. L DATE: 2017. 3. 1
CHECKED: C. W DATE: 2017. 3. 1
APPROVED: C. W DATE: 2017. 3. 1

TITLE: DUAL USB 3.1 C FEMALE CONNECTOR DIP TYPE

MATERIAL: PART NO: U06-DCF2X5T-001 SIZE: A4
FINISH: DWG NO: U06-DCF2X5T-001 SHEET: 1 OF 3

REV: A UNIT mm SCALE 1=1 QUALITY SYMBOLS

RoHS Compliant

REVISIONS			
REV.	DESCRIPTION	DATE	DESIGN

USB TYPE-C FULL-FEATURED RECEPTACLE INTERFACE PIN ASSIGNMENTS

PIN	Signal Name	Description	PIN	Signal Name	Description
A1	GND	Ground return	B12	GND	Ground return
A2	SSTXp1	Positive half of first SuperSpeed TX differential pair	B11	SSRXp1	Positive half of first SuperSpeed RX differential pair
A3	SSTXn1	Negative half of first SuperSpeed TX differential pair	B10	SSRXn1	Negative half of first SuperSpeed RX differential pair
A4	VBUS	Bus Power	B9	VBUS	Bus Power
A5	CC1	Configuration Channel	B8	SBU2	Sideband Use (SBU)
A6	Dp1	Positive half of the USB 2.0 differential pair-Position 1	B7	Dn2	Negative half of the USB 2.0 differential pair-Position 2
A7	Dn1	Negative half of the USB 2.0 differential pair-Position 1	B6	Dp2	Positive half of the USB 2.0 differential pair-Position 2
A8	SBU1	Sideband Use (SBU)	B5	CC2	Configuraaion Channel
A9	VBUS	Bus Power	B4	VBUS	Bus Power
A10	SSRXn2	Negative half of second SuperSpeed RX differential pair	B3	SSTXn2	Negative half of second SuperSpeed TX differential pair
A11	SSRXp2	Positive half of second SuperSpeed RX differential pair	B2	SSTXp2	Positive half of second SuperSpeed TX differential pair
A12	GND	Ground return	B1	GND	Ground return

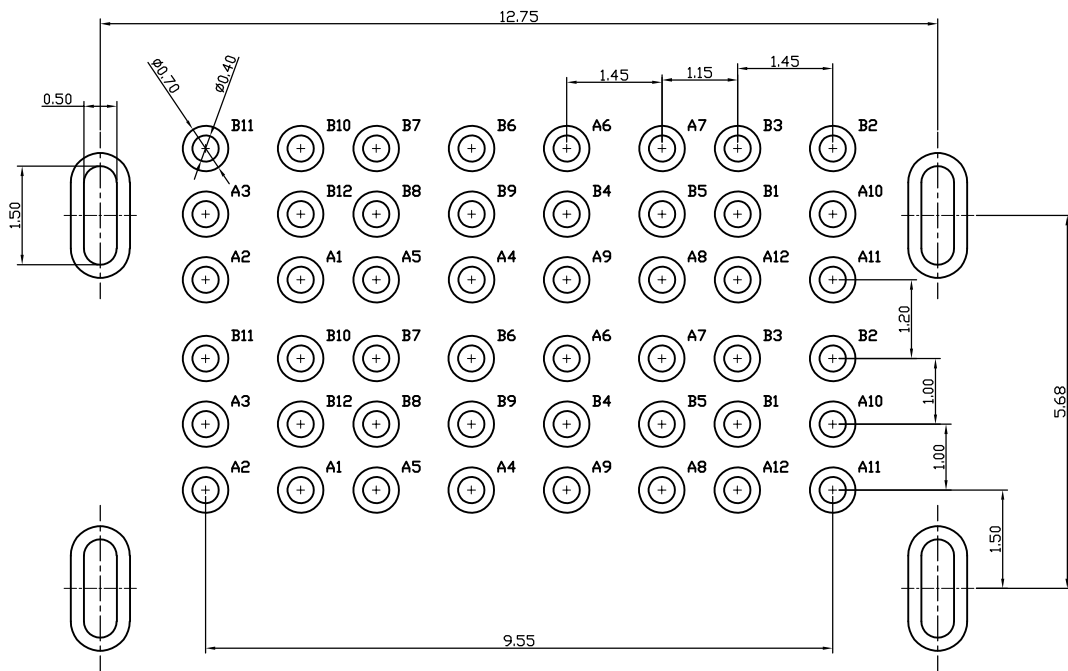

RECOMMENDED PCB LAYOUT(TOP VIEW)
(DEFAULT TOLERANCE:±0.05)

Bestcreate Technology Limited

TOLERANCES UNLESS OTHERWISE SPECIFIED:

X.	± 0.50	X.*	± 3°
.X	± 0.30	.X*	± 2°
.XX	± 0.20	.XX*	± 1°

DESIGN: I. L DATE: 2017. 3. 1

CHECKED: C. W DATE: 2017. 3. 1

APPROVED: C. W DATE: 2017. 3. 1

TITLE: DUAL USB 3.1 C FEMALE CONNECTOR DIP TYPE

MATERILA: PART NO: U06-DCF2X5T-001 SIZE: A4

FINSH: DWG NO: U06-DCF2X5T-001 SHEET: 2 OF 2

REV: A UNIT mm SCALE 1=1 QUALITY SYMBOLS

Website: www.bsc-elec.com
E-mail: bestcreate@bsc-elec.com

RoHS Compliant

REVISIONS			
REV.	DESCRIPTION	DATE	DESIGN

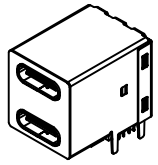

產品

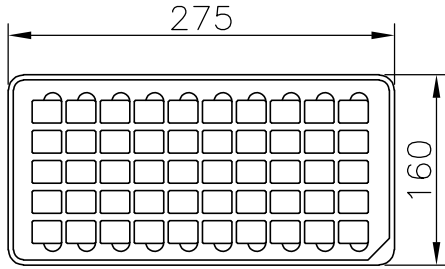

1、將產品整齊擺放脆盤中,共50PCS.

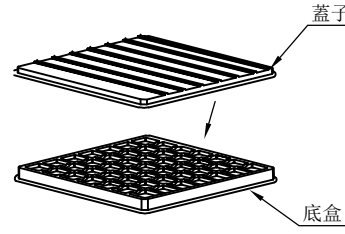

2、裝滿一盤產品後,將蓋子蓋上。

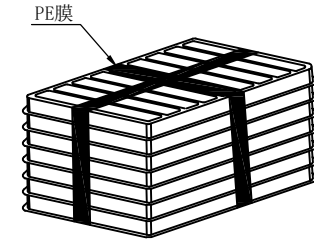

3、將裝滿產品的脆盤疊放14層;然後用打包膜捆綁(共700PCS)。

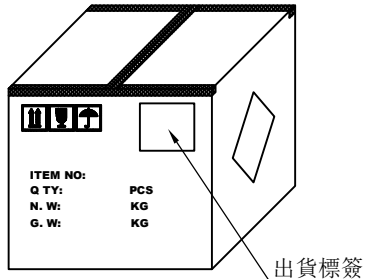

1400PCS/Ī?

6、用膠紙工字型封住紙箱,一共1400PCS產品。

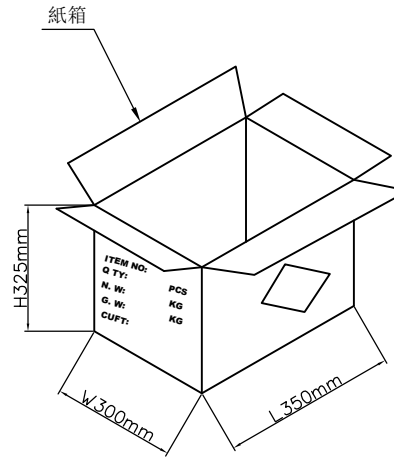

5、將產品2捆並排放入紙箱,上下各放一紙板。

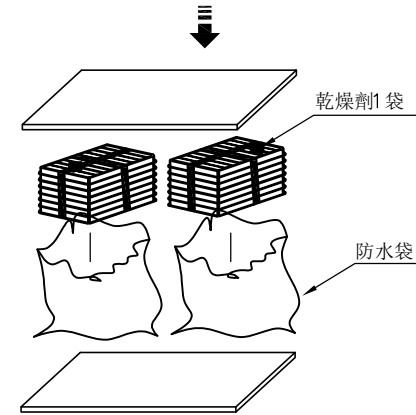

4、將每14層捆綁好的產品裝入一個防水袋,加入一袋干燥劑。

作業步驟:

- 1、將產品整齊放入脆盤中,共50PCS,再蓋上蓋子。
- 2、將裝滿50PCS產品的脆盤疊放14盤,用打包膜捆綁。
- 3、將捆綁好的產品放入防水袋中,再放入1袋干燥劑,膠帶封口(共700PCS)。
- 4、在紙箱底先放一個紙板,然後將捆好的產品並排放入紙箱,頂層再放一個紙板。
- 5、合上紙箱後,再用膠帶工字型將紙箱封口,整箱共1400PCS產品。
- 6、貼上出貨標籤,如有零數箱需做標識。
- 7、紙箱材質尺寸: K=K 350*300*325mm (內徑)
脆盤材質尺寸: PS防靜電 275*160*14.5mm

Bestcreate Technology Limited

TOLERANCES UNLESS OTHERWISE SPECIFIED:

X.	± 0.50	X.*	± 3"
.X	± 0.30	.X*	± 2"
.XX	± 0.20	.XX*	± 1"

Website: www.bsc-elec.com
E-mail: bestcreate@bsc-elec.com

DESIGN: I. L DATE: 2017. 3. 1

CHECKED: C. W DATE: 2017. 3. 1

APPROVED: C. W DATE: 2017. 3. 1

TITLE: DUAL USB 3.1 C FEMALE CONNECTOR DIP TYPE

MATERILA: PART NO: U06-DCF2X5T-001 SIZE: A4

FINSH: DWG NO: U06-DCF2X5T-001 SHEET: 3 OF 3

REV: A UNIT mm SCALE 1=1 QUALITY SYMBOLS