

RoHS Compliant

REVISIONS			
REV.	DESCRIPTION	DATE	DESIGN

COLOR	PLATING
BLACK	NICKEL
SLIVER	NICKEL
GOLD	NICKEL
GRAY	NICKEL
ROSE GOLD	NICKEL

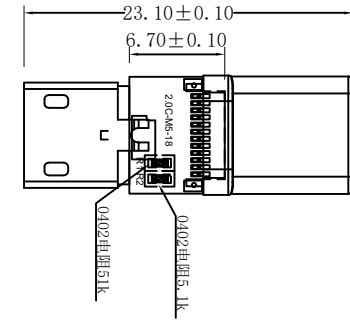
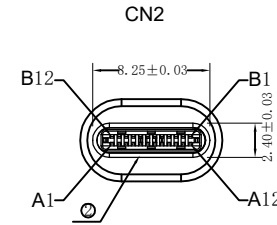
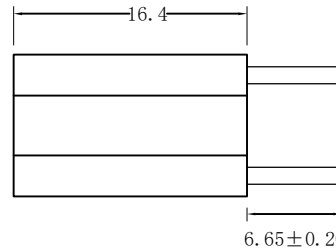
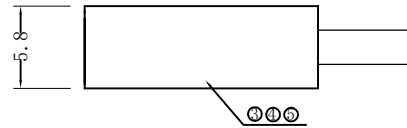
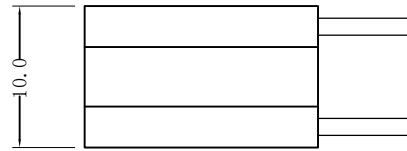
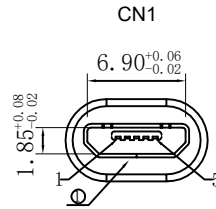

CONTACT

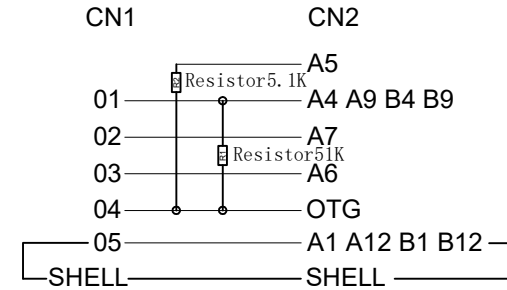

NOTES:

- 100% open short test condition;
- Conductor Resistance $\leq 5 \Omega$, insulation resistance $\geq 10M \Omega$. High voltage test, DC 300V/10mS.
- Support Power Charging、Data Transfer.
- PCB Board Connection.

5	SHELL	Aluminium Alloy	5.10.91-95	1.1G
4	Internal Mold	PVC 45P BLACK	5.09.02-1	1.2G
3	In-Connection	PCB T=0.8MM 1*Resistor5.1K 1*Resistor51K	5.12.220	1PCS
2	Connector	USB TYPE CM SHELL PEARL NICKEL PIN G/F	5.03.69	1PCS
1	Connector	USB MICRO BF SHELL NICKEL PLATED PIN G/F	5.03.37	1PCS
NO	NAME	MATERIAL	NO	QTY

Bestcreate Technology Limited

TOLERANCES UNLESS OTHERWISE SPECIFIED:

X.	± 0.50	X.*	± 5°
.X	± 0.30	.X*	± 2°
.XX	± 0.10	.XX*	± 1°

Website: www.bsc-elec.com
Email: bestcreate@bsc-elec.com

DESIGN: I. L DATE: 2017.3.1

CHECKED: C. W DATE: 2017.3.1

APPROVED: C. W DATE: 2017.3.1

TITLE: USB3.1 TYPE CM TO MICRO BF

MATERILA:	PART NO: AD31CMMBF-019	SIZE: A4
FINSH:	DWG NO: AD31CMMBF-019	

REV: A	UNIT mm	SCALE 1=1	QUALITY SYMBOLS	
--------	---------	-----------	-----------------	--