

RoHS Compliant

REVISIONS			
REV.	DESCRIPTION	DATE	DESIGN

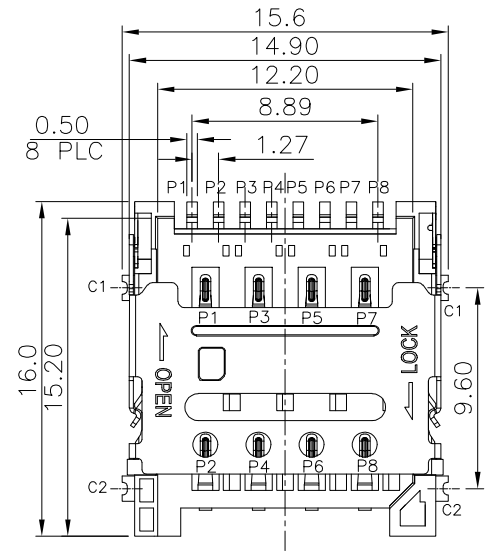

NOTES:  
 1) MATERIAL:  
 HOUSING: LCP S475 UL 94V-0  
 CONTACT: C5210-EH T=0.15mm  
 SHELL: SUS201-H T=0.20mm  
 2) FINISH:  
 CONTACT: GOLD FLASH PLATED ON CONTACT AREA 1u"Min ;  
 GOLD FLASH PLATING ON SOLDER TAILS 1u"Min,  
 WITH ENTIRE CONTACT UNDERPLATED NICKEL 30u"Min  
 SHELL: NICKEL UNDERPLATED OVERALL 50u"Min,  
 3) MECHANICAL CHARACTERISTICS  
 CONTACT RETENTION: 50gf/pin Min  
 MATING CYCLE: 3000 CYCLES  
 4) ELECTRICAL CHARACTERISTICS  
 RATING CURRENT: 1A  
 RATING VOLTAGE: 30V  
 CONTACT RESISTANCE: 50 MILLOHMS OHMS MAX  
 INSULATION RESISTANCE:  
 a, UNMATED: 1000M OHMS MIN  
 b, MATED: 100M OHMS MIN  
 DIELECTRIC WITHSTANDING VOLTAGE:  
 500V AC/1MINUTE  
 OPERATING TEMPERATURE: -25° C→+70° C  
 STORAGE TEMPERATURE: -10° C→+40° C

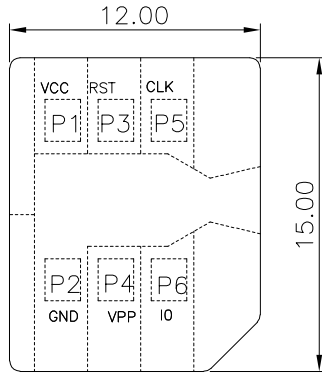
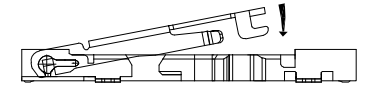
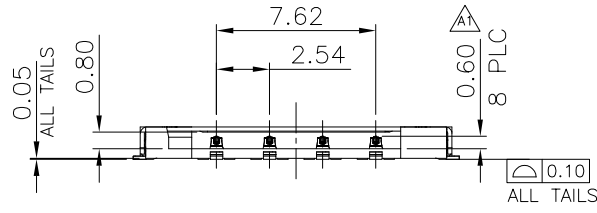
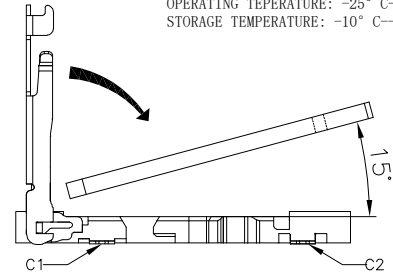
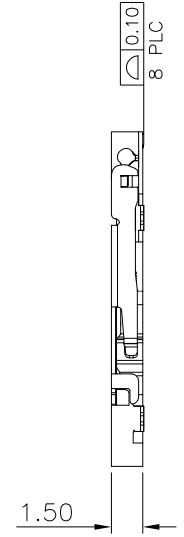

芯片面朝下视图

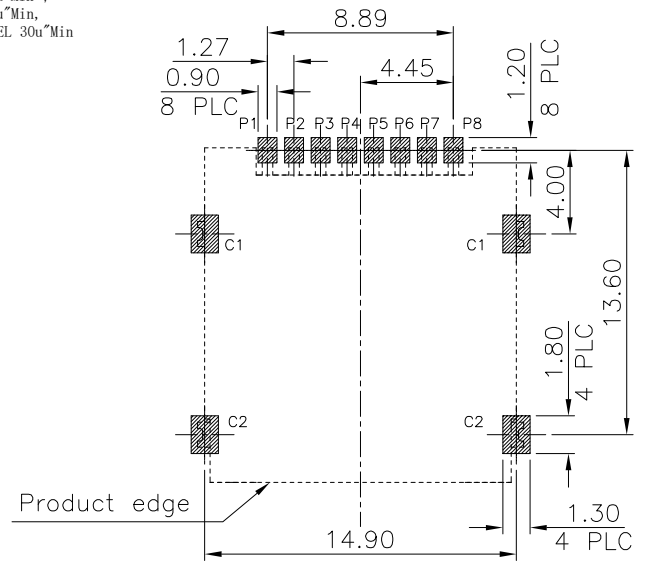

RECOMMENDED PCB LAYOUT(TOP VIEW)  
 GENERAL TOLERANCES: ±0.05

PART NO. INFORMATION

**MCSIM - 08 X X 5 R - 007**

08:8P  
 CONTACT PLATED  
 1: GOLD FLASH  
 2: GOLD 3U"  
 3: GOLD 5U"  
 4: GOLD 10U"  
 5: GOLD 15U"  
 6: GOLD 30U"  
 PACKAGE  
 R: TAPE REEL  
 HOUSING COLOR  
 2: WHITE  
 5: BLACK  
 9: NATURE  
 HOUSING MATERIAL  
 A: LCP B: PBT  
 C: PA9T D: PA6T  
 E: PA46 F: PA66

MICRO SIM CARD	
PIN NO.	DESCRIPTION
P1	VCC
P2	GND
P3	RST
P4	VPP
P5	CLK
P6	I/O
P7	RESERVED
P8	RESERVED

**Bestcreate Technology Limited**

TOLERANCES UNLESS OTHERWISE SPECIFIED:  

.X ± 0.35	X' ± 5'
.XX ± 0.25	.X' ± 2'
.XXX ± 0.15	.XX' ± 1'

 Website: www.bsc-elec.com  
 Email: bestcreate@bsc-elec.com

DESIGN: I. L  
 DATE: 2017. 3. 1  
 CHECKED: C. W  
 DATE: 2017. 3. 1  
 APPROVED: C. W  
 DATE: 2017. 3. 1

TITLE: MICRO SIM CARD 8PIN 1.5H  
 (FLIP TYPE 8X1PIN)  
 MATERIAL: FINISH:  
 PART NO: MCSIM-08XX5R-007  
 DWG NO: MCSIM-08XX5R-007  
 SIZE: A4  
 1 OF 2

REV: A	UNIT: mm	SCALE: 1=1	QUALITY SYMBOLS
--------	----------	------------	-----------------

RoHS Compliant

REVISIONS			
REV.	DESCRIPTION	DATE	DESIGN

<图一>

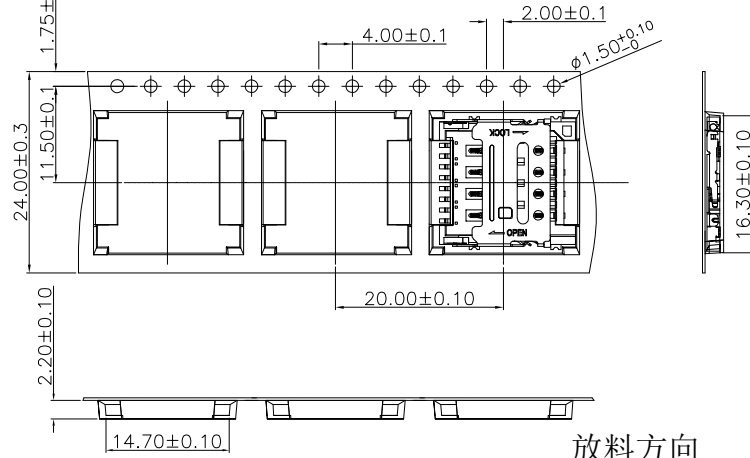

<TABLE 1> PACKAGING QUANTITY

QTY/REEL	REEL/CARTON	QTY/CARTON
1250	10	12500

<图三>

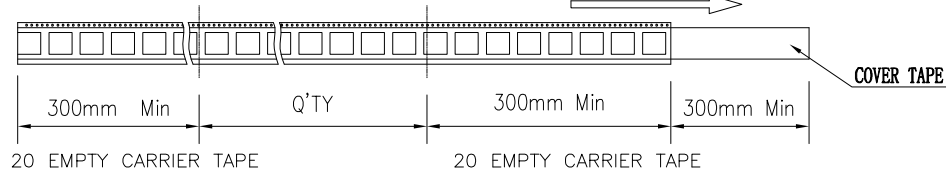
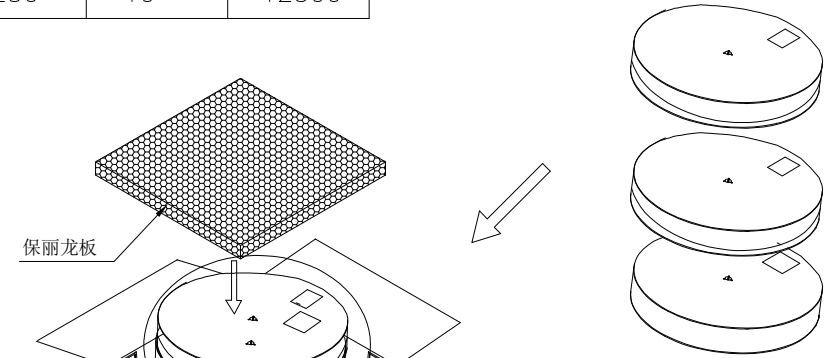

COVER TAPE PEELING FORCE: 50gf~150gf

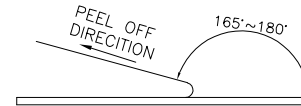

<图二>

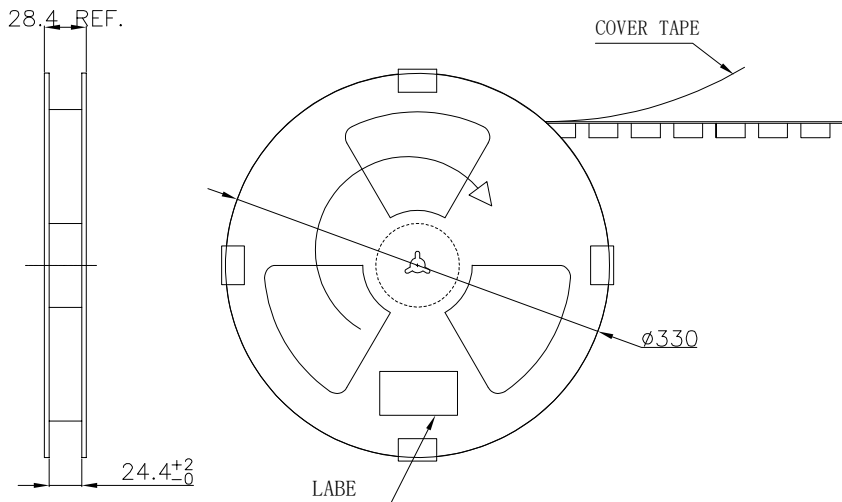

NOTE:

1. 依<图一>示放置产品于下载中, 每穴放置1PCS产品.
2. 包装机包好后, 在REEL的个等分点贴上胶带, 以防止REEL张开, 每REEL贴1PCS标签, 如<图二>示
3. 包装数量见如<TABLE 1>示
4. 包装成箱见如<图三>示  
箱底放保丽龙板, 再依次将指定数量的卷装产品用防水袋装好放入箱内;  
四角分别放入四个三角护板, 最上层再放上保丽龙板.
5. 封箱, 在封好的纸箱上按客户要求写上料号, 数量等

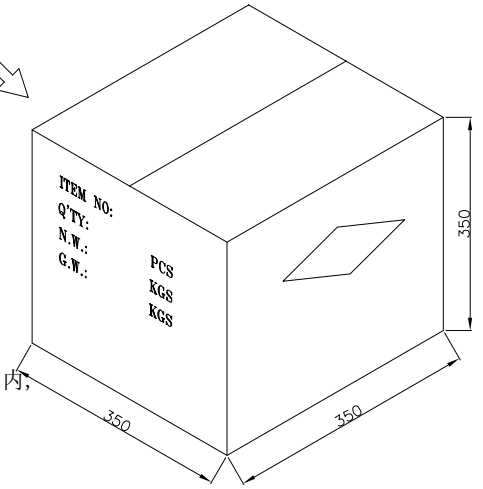

**Bestcreate Technology Limited**

TOLERANCES UNLESS OTHERWISE SPECIFIED:					
.X	±	0.35	X'	±	5'
.XX	±	0.25	.X'	±	2'
.XXX	±	0.15	.XX'	±	1'
Website: www.bsc-elec.com					
Email: bestcreate@bsc-elec.com					

DESIGN:	DATE:
I. L	2017. 3. 1
CHECKED:	DATE:
C. W	2017. 3. 1
APPROVED:	DATE:
C. W	2017. 3. 1

TITLE: MICRO SIM CARD 8PIN 1.5H (FLIP TYPE 8X1PIN)		
MATERILA:	PART NO:	SIZE:
FINSH:	DWG NO:	2 OF 2
	MCSIM-08XX5R-007	A4
	MCSIM-08XX5R-007	

REV: A	UNIT mm	SCALE 1=1	QUALITY SYMBOLS
--------	---------	-----------	-----------------