

RoHS Compliant

REVISIONS			
REV.	DESCRIPTION	DATE	DESIGN

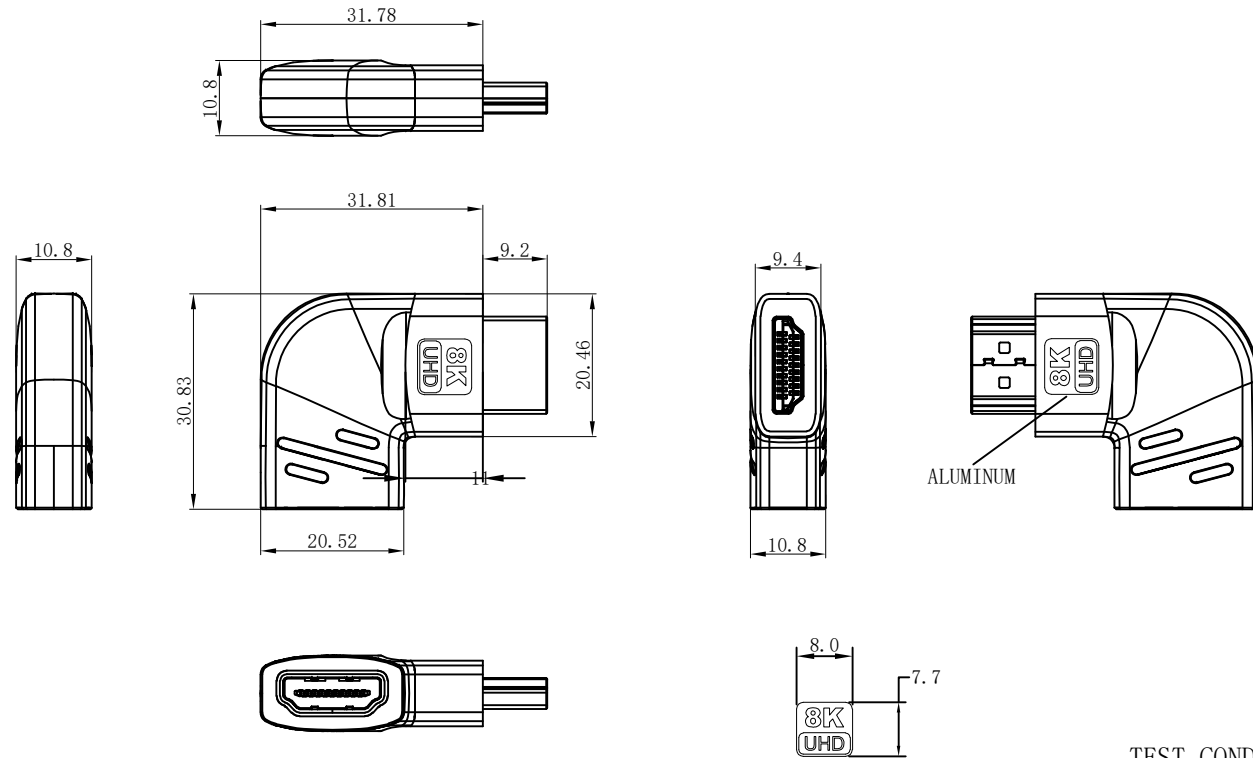

HDMI WIRING TABLE

P1	P2
1	1
3	3
2	2
4	4
6	6
5	5
7	7
9	9
8	8
10	10
12	12
11	11
14	14
19	19
17	17
13	13
15	15
16	16
18	18
外壳	外壳

ITEM	MATERIAL	SPECIFICATION	UNIT	QTY
7	PACKAGE	SELF SEAL ZIPPER PE BAG	pcs	1
6	PVC MATERIAL	45P CAL65 N18P ENVIRONMENTAL MATERIAL	g	6
5	PE MATERIAL	PE LOW DENSITYTYPE INTERNAL MOLD MATERIAL	g	3
4	ALUMINUM SHELL	BLACK ALUMINUM SHELL9.4mm*11mm*20.46mm NETC LOGO	pcs	2
3	PCBA	4 LAYER PCBA	pcs	1
2	CONNECTOR	HDMI AM SPCC SHELL WITH GOLD PLATING, 3U'' ON CONTACT, STRADDLE MOUNT	PCS	1
1	CONNECTOR	HDMI AF SPCC SHELL WITH GOLD PLATING, 3U'' ON CONTACT, STRADDLE MOUNT	PCS	1

TEST CONDITION:

- a. 100% SHORT CIRCUIT/OPEN CIRCUIT TEST.
- b. DC:300V AC:200V INSULATION RESISTANCE:10MΩ
- c. CONDUCTOR RESISTANCE : ≤5Ω
- d. 8K\*4K 60HZ VEDIO AND AUDIO TEST.

**Bestcreate Technology Limited**

TOLERANCES UNLESS OTHERWISE SPECIFIED:		DESIGN: I.L	DATE: 2017.3.1	TITLE: HDMI AM TO AF 8K ALUMINUM SHELL ADAPTER 270°	
X. ± 0.50	X.' ± 5'	CHECKED: C.W	DATE: 2017.3.1	MATERILA:	PART NO: HDAMAF8K-004
.X ± 0.30	.X' ± 2'	APPROVED: C.W	DATE: 2017.3.1	FINSH:	DWG NO: HDAMAF8K-004
.XX ± 0.10	.XX' ± 1'	Website:www.bsc-elec.com		SIZE: A4	
Email:bestcreate@bsc-elec.com					

REV: A	UNIT mm	SCALE 1=1	QUALITY SYMBOLS
--------	---------	-----------	-----------------