

RoHS Compliant

REVISIONS			
REV.	DESCRIPTION	DATE	DESIGN

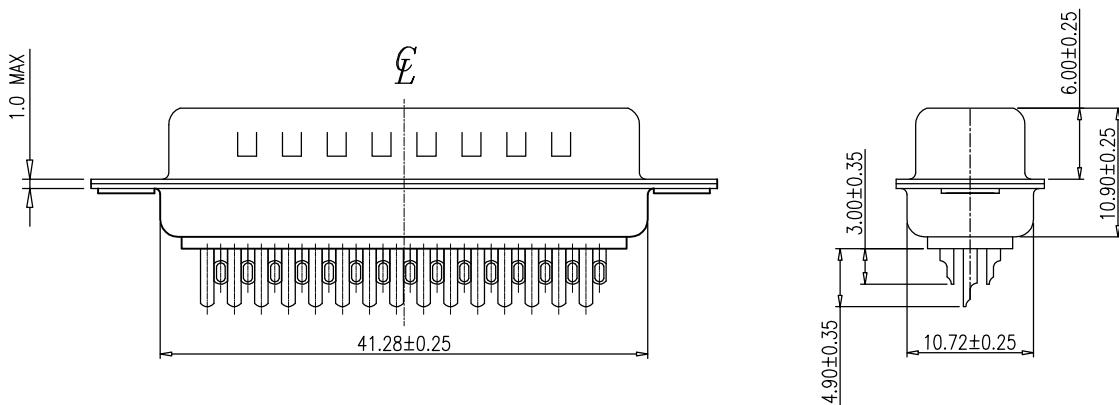
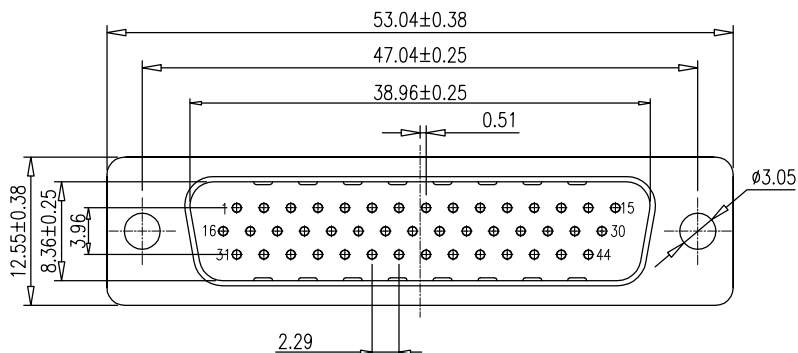

- NOTE:
- MATERIALS AND FINISHED  
 INSULATOR : PBT+30% GF UL 94V-0,  
 SHELL : STEEL, NI OR SN FINISHED  
 CONTACT MATERIAL : BRASS, SELEVITE GOLD FINISHED  
 RIVETED INSERT: BRASS MATERIAL ,TIN FINISHED  
 WITH #4-40 THREADED ASSEMBLED
  - ELECTRICAL CHARACTERISTICS  
 CURRENT RATING : 3.0 AMP DC  
 VOLTAGE RATING: 250 V DC  
 CONTACT RESISTANCE :30 MILLIOHMS MAX.  
 DIELECTRIC WITHSTANDING VOLTAGE : 1000 V AC MIN.  
 INSULATION RESISTANCE : 1000 MEGAOHMS MIN.
  - ENVIRONMENTAL  
 OPERATING TEMPERATURE: -55°C ~ +85°C  
 STORAGE TEMPERATURE:-55°C ~ +105°C
  - HOW TO ORDER:

HBM111-44XXXXP-AOX10

Male

15:15Pin 26:26PIN  
 44:44Pin 62:62PIN

G:Full Gold  
 S:Selevite Gold Bright TIN

1:G/F" 3: 3u"  
 2:2u" 6: 10u"

1. Front NI Back SN  
 3. Full Sn  
 5. Full NI

0: RoHs

7:Front rivet Solid nut(Iron)  
 5:Front rivet Solid nut(Copper)  
 2:Front rivet hollow nut(Copper)  
 1:Back rivet hollow nut(Copper)  
 0:Ø3.05 through Hole

A:No screw type  
 (Riveting Type)

P:PBT

L: Light blue  
 U: Blue(661C)  
 B: Black  
 W: White

**Bestcreate Technology Limited**

TOLERANCES UNLESS OTHERWISE SPECIFIED:

.X	± 0.35	X.	± 3"
.XX	± 0.25	.X.	± 2"
.XXX	± 0.15	.XX.	± 1"

Website:www.bsc-elec.com  
 Email:bestcreate@bsc-elec.com

DESIGN: I.L DATE: 2017.3.1

CHECKED: C.W DATE: 2017.3.1

APPROVED: C.W DATE: 2017.3.1

TITLE: HDB-44P MALE CONNECTOR FOR WIRE SOLDERING

MATERILA:	PART NO: HBM111-44XXXXP-AOX10	SIZE: A4
FINSH:	DWG NO: HBM111-44XXXXP-AOX10	

REV: A	UNIT mm	SCALE 1=1	QUALITY SYMBOLS
--------	---------	-----------	-----------------