

RoHS Compliant

REVISIONS			
REV.	DESCRIPTION	DATE	DESIGN

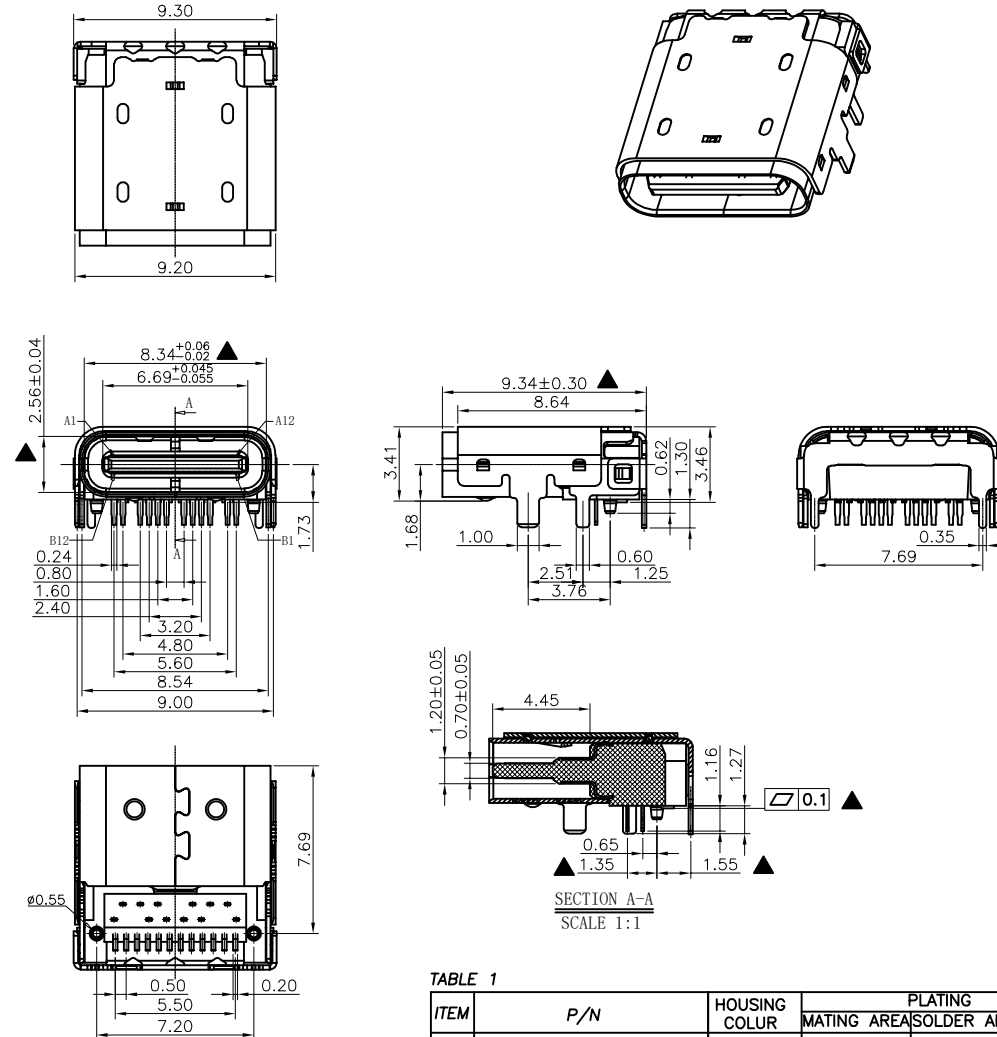

NOTE:

- MATERIAL SPECIFICATION:
 - HOUSING:LCP COLOR SEE TABLE 1,UL94 V-0.
 - CONTACTS:COPPER ALLOY
 - MID PLATE&SPRING: STAINLESS STEEL(SUS301)
 - FRONT SHELL&COVER: STAINLESS STEEL(SUS304)
- PLATING SPECIFICATION:
 - CONTACTS:
 - Ni 50u" MIN. UNDER PLATED OVER ALL.
 - Au PLATED ON THE FUNCTIONAL AREA OF CONTACT. (GOLD PLATING THICKNESS FOLLOW THE P/N)
 - FRONT SHELL & COVER:
 - Ni 30u" MIN. UNDER PLATED OVER ALL.
 - MID PLATE & EMI SPRING:
 - CLEAR ONLY
- MECHANICAL PERFORMANCE,
 - INSERTION FORCE: 0.5~2.0kgf.
 - REMOVAL FORCE: 0.8kgf~2.0kgf.
 - DURABILITY: 10000 CYCLES.
- ELECTRICAL PERFORMANCE,
 - CURRENT RATING:3.0A
VOLTAGE RATING:5.0V
 - LLCR:
 - VBUS & GND PINS AND OTHER PINS: 40mΩ/PIN MAX.
 - SHIELD: 50mΩ/MAX.
 - LLCR MAX. CHANGE OF ALL PINS: 10mΩ.
 - INSULATION RESISTANCE: 100MΩ MIN
 - DIELECTRIC WITHSTAND VOLTAGE,AC 100V FOR 1 MINUTE.
- ENVIRONMENTAL PERFORMANCE:
 - OPERATING TEMPERATURE: -25°C~+85°C.
 - REFLOW:
 - THE PEAK TEMPERATURE ON THE BOARD SHALL BE MAINTAINED FOR 10 SECONDS AT 260°C.
- 注: 带“▲”号的为重点管控尺寸

PART NO. INFORMATION

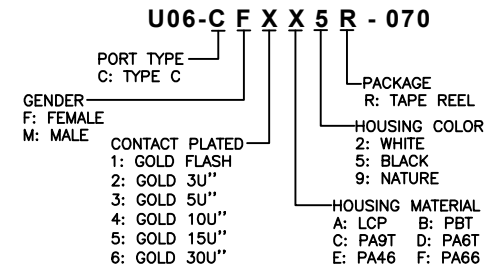

TABLE 1

ITEM	P/N	HOUSING COLUR	PLATING	
			MATING AREA	SOLDER AREA
1	U06-CF2A5R-070	BALCK	Au:3u"	Au:G/F
2	U06-CF6A5R-070	BALCK	Au:30u"	Au:G/F

Bestcreate Technology Limited

TOLERANCES UNLESS OTHERWISE SPECIFIED:

X.	± 0.50	X.'	± 5'
.X	± 0.38	.X'	± 2'
.XX	± 0.25	.XX'	± 1'

Website:www.bsc-elec.com
Email:bestcreate@bsc-elec.com

DESIGN:
I. L

DATE:

CHECKED:
C. W

DATE:

APPROVED:
C. W

DATE:

TITLE:

24P USB 3.1 C FEMALE CONNECTOR DIP+SMT

MATERILA:

PART NO:

U06-CFXX5R-070

SIZE: A4

FINSH:

DWG NO:

U06-CFXX5R-070

REV:
A

UNIT
mm

SCALE
1=1

QUALITY
SYMBOLS

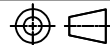

RoHS Compliant

REVISIONS			
REV.	DESCRIPTION	DATE	DESIGN

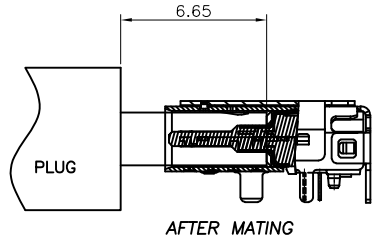

USB TYPE-C PIN ASSIGNMENTS

PIN NUMBER	SIGNAL NAME	PIN NUMBER	SIGNAL NAME
A1	GND	B12	GND
A2	SSTXp1	B11	SSRXp1
A3	SSTXn1	B10	SSRXn1
A4	Vbus	B9	Vbus
A5	CC1	B8	SBU2
A6	Dp1	B7	Dn2
A7	Dn1	B6	Dp2
A8	SBU1	B5	CC2
A9	Vbus	B4	Vbus
A10	SSRXn2	B3	SSTXn2
A11	SSRXp2	B2	SSTXp2
A12	GND	B1	GND

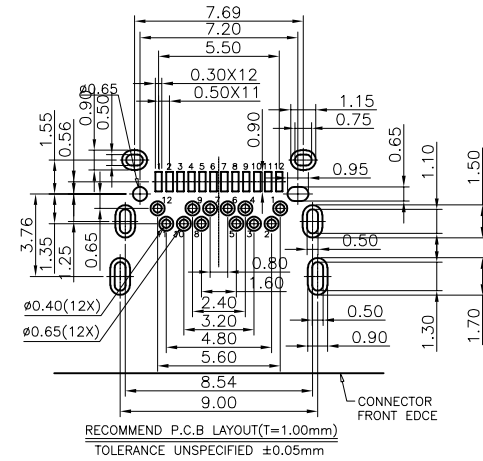

Bestcreate Technology Limited

TOLERANCES UNLESS OTHERWISE SPECIFIED:

X.	± 0.50	X.'	± 5'
.X	± 0.38	.X'	± 2'
.XX	± 0.25	.XX'	± 1'

DESIGN: I. L DATE:

CHECKED: C. W DATE:

APPROVED: C. W DATE:

TITLE: 24P USB 3.1 C FEMALE CONNECTOR DIP+SMT

MATERILA: PART NO: U06-CFXX5R-070 SIZE: A4

FINSH: DWG NO: U06-CFXX5R-070

REV: A UNIT: mm SCALE: 1=1 QUALITY SYMBOLS:

Website: www.bsc-elec.com
Email: bestcreate@bsc-elec.com

RoHS Compliant

REVISIONS			
REV.	DESCRIPTION	DATE	DESIGN

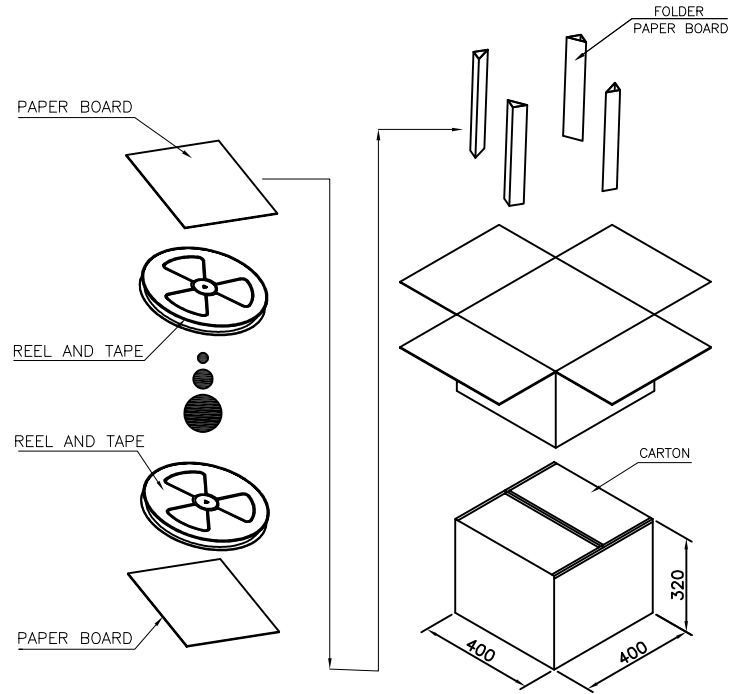
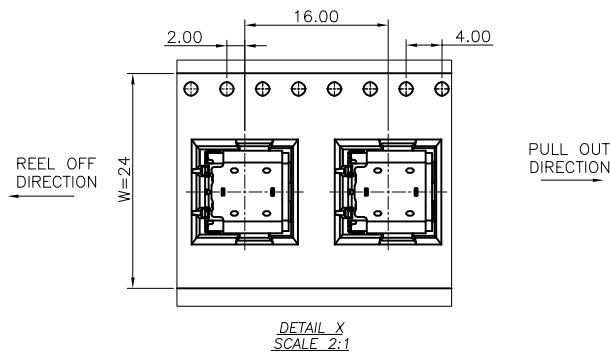
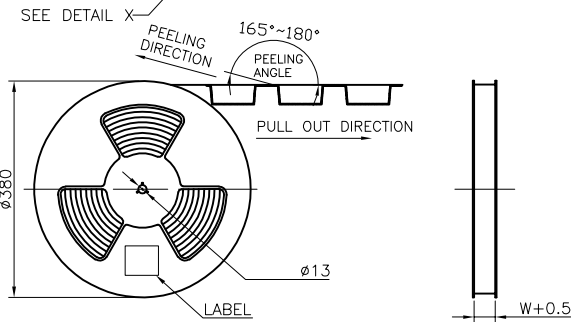
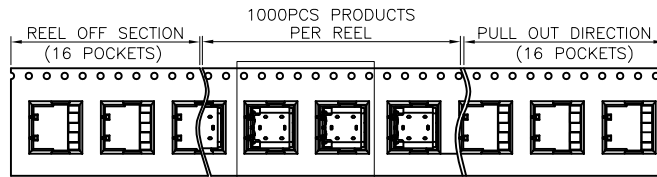

	REEL/TRAY	CARTON
CONNECTOR (PCS)	1000	10000

Bestcreate Technology Limited

TOLERANCES UNLESS OTHERWISE SPECIFIED:

X.	± 0.50	X.'	± 5'
.X	± 0.38	.X'	± 2'
.XX	± 0.25	.XX'	± 1'

Website: www.bsc-elec.com
 Email: bestcreate@bsc-elec.com

DESIGN: I. L DATE:

CHECKED: C. W DATE:

APPROVED: C. W DATE:

TITLE: 24P USB 3.1 C FEMALE CONNECTOR DIP+SMT

MATERIAL: PART NO: U06-CFXX5R-070 SIZE: A4

FINISH: DWG NO: U06-CFXX5R-070

REV: A UNIT: mm SCALE: 1=1 QUALITY SYMBOLS