

RoHS Compliant

REVISIONS			
REV.	DESCRIPTION	DATE	DESIGN

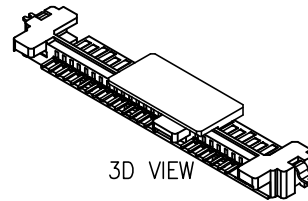
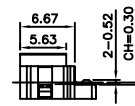
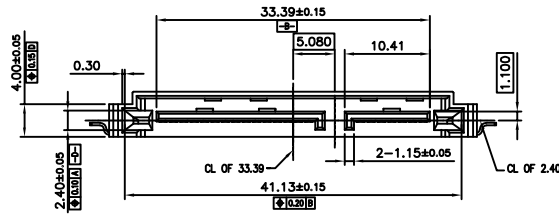
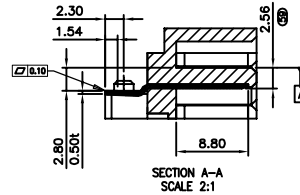
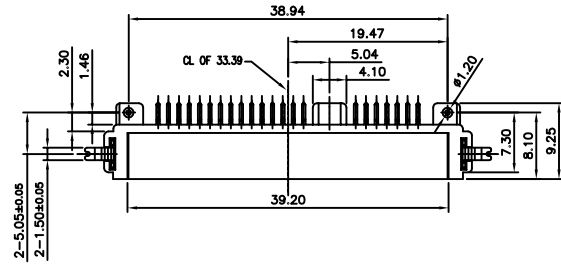

3D VIEW

NOTES:

1. MATERIAL

- 1.1. HOUSING: HIGH TEMPERATURE THERMOPLASTIC UL94V-0 BLACK;
- 1.2. CAP: HIGH TEMPERATURE THERMOPLASTIC UL94V-0 BLACK;
- 1.3. CONTACT: BRASS C2680R T=0.25
- 1.4. PEG: BRASS C2680R T=0.30

2. FINISH:

2.1 CONTACT:

- 5u" GOLD (SEE TABLE) PLATING ON CONTACT AREA.
- 2.54um [100u"] MIN. TIN PLATING ON SOLDER TAIL AREA.
- 1.27um [50u"] MIN. NICKEL UNDERPLATING ON ALLOVER AREA.

2.2 PEG

- 2.54um [100u"] MIN TIN PLATING OVERALL
- 1.27um [50u"] MIN NICKEL UNDERPLATING OVERALL

3. RECOMMENDED PCB THICKNESS : 1.05mm

4. APPLIED TO REFLOW SOLDERING PROCESS

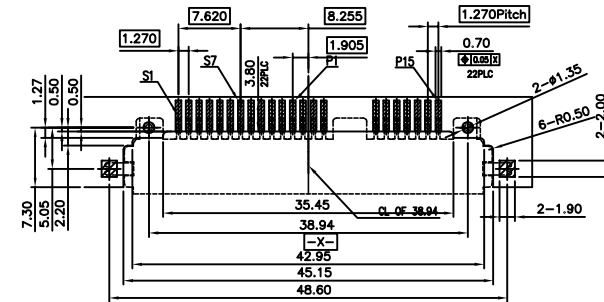

RECOMMEND P.C.B LAYOUT (COMPONENT SIDE)
TOLERANCES: ±0.05; PCB THICKNESS: 1.05mm (TOP VIEW)

PART NO. INFORMATION

S715 - M X A 5 T -005

GENDER
F: FEMALE
M: MALE

CONTACT PLATED
1: GOLD FLASH/TIN
2: 15U" GOLD/TIN
3: 30U" GOLD/TIN

PACKAGE
T: TRAY
R: TAPE REEL
HOUSING COLOR
5: BLACK
HOUSING MATERIAL
A: LCP

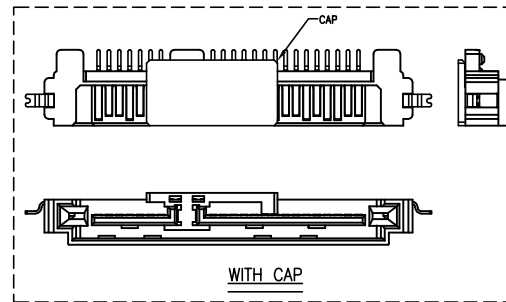
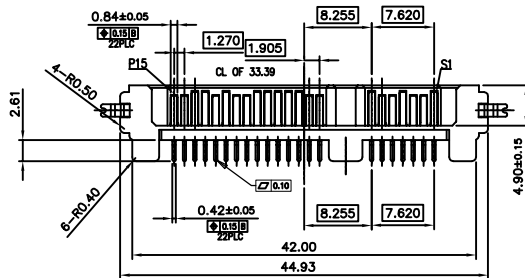

WITH CAP

Bestcreate Technology Limited

TOLERANCES UNLESS OTHERWISE SPECIFIED:

X.	± 0.35	X.*	± 3*
.X	± 0.25	.X*	± 2*
.XX	± 0.15	.XX*	± 1*

Website: www.bsc-elec.com

E-mail: bestcreate@bsc-elec.com

DESIGN: I. L
DATE: 2017. 3. 1

CHECKED: C. W
DATE: 2017. 3. 1

APPROVED: C. W
DATE: 2017. 3. 1

TITLE: SATA 7+15P MALE SMT
TYPE 5U" 三面包

MATERIAL:	PART NO: S715-MXA5T-005	SIZE: A4
FINISH:	DWG NO: S715-MXA5T-005	SHEET: 1 OF 2

REV: A	UNIT mm	SCALE 1=1	QUALITY SYMBOLS
--------	---------	-----------	-----------------

RoHS Compliant

REVISIONS			
REV.	DESCRIPTION	DATE	DESIGN

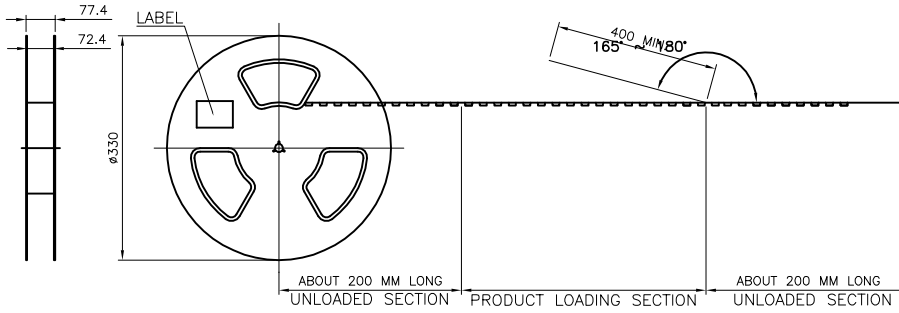

- NOTES :
- PACKAGING MATERIAL IN PLASTIC, RUBBER, INK, PIGMENT AND PAINT MUST MEET DEREN CONTROLLED SUBSTANCES SPEC.
 - * CADMIUM AND CADMIUM COMPOUNDS NOT TO EXCEED: 5 PPM.
 - * LEAD, CADMIUM, CHROM VI AND MERCURY NOT TO EXCEED: 100 PPM (COMBINED).
 - * CARRIER TAPES, COVER TAPES, REELS AND TAPED COMPONENTS MUST MEET THE REQUIREMENTS DEFINED PER EIA-481-B.
- MATERIAL :
COVER TAPE : PET, COLOR: NATURE
CARRIER TAPE : PS COLOR:BLACK
REEL : PS COLOR: BLUE
SHIPPING BOX: CORRUGATED FIBER
PARTITION BOARD: CORRUGATED FIBER
 - DIMENSION :
REEL : SEE DRAWING
BOX : SEE DRAWING
 - QUANTITY :
 - WEIGHT :
 - PEELING RESISTANCE:10gf~150gf (for 72mm)
 - PEELING SPEED : 300mm/MINUTES

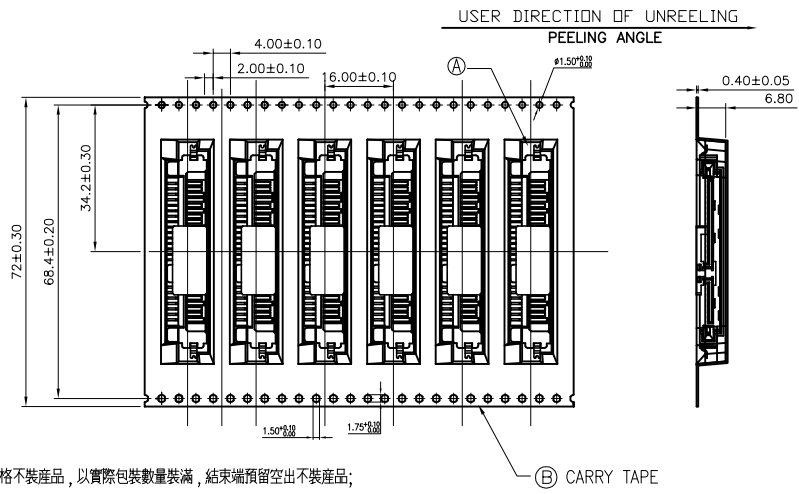

Notes:

- 每卷卷帶的開始端留 10PCS 空格不裝產品,以實際包裝數量裝滿,結束端預留空出 不裝產品;
- 卷帶用自封膠帶封口, 1個卷盤放置 650PCS 產品;
- 再繞一圈保護帶,保護帶最後重疊約 50mm,每個卷盤須貼一張物料標籤和無齒標籤;
- 將PE袋套入外箱後,四個角各放入一塊護角板;
- 將 4盤 裝好產品的卷盤依次放入紙箱,並在紙箱對角各放入乾燥劑一袋,然後再放置一塊隔板;
- 外箱外側以膠帶封口,每個外箱外側圖示位置各貼一張物料標籤;
- 包裝數量: 650PCS/REEL, 4REEL/CARTON,共 2600PCS/CARTON;
- 此部品必須符合ROHS指令要求。
- 儲存在通風,干燥環境,搬運輕拿輕放。

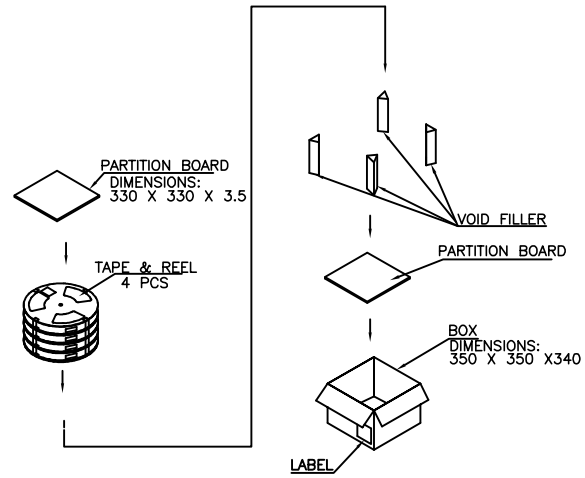

Bestcreate Technology Limited

TOLERANCES UNLESS OTHERWISE SPECIFIED:

X.	± 0.35	X.*	± 3*
.X	± 0.25	.X*	± 2*
.XX	± 0.15	.XX*	± 1*

Website: www.bsc-elec.com
E-mail: bestcreate@bsc-elec.com

DESIGN: I. L DATE: 2017. 3. 1

CHECKED: C. W DATE: 2017. 3. 1

APPROVED: C. W DATE: 2017. 3. 1

TITLE: SATA 7+15P MALE SMT
TYPE 5U'' 三面包

MATERIAL:	PART NO: S715-MXA5T-005	SIZE: A4
FINISH:	DWG NO: S715-MXA5T-005	SHEET: 1 OF 2

REV: A	UNIT mm	SCALE 1=1	QUALITY SYMBOLS
--------	---------	-----------	-----------------