

RoHS Compliant

REVISIONS			
REV.	DESCRIPTION	DATE	DESIGN

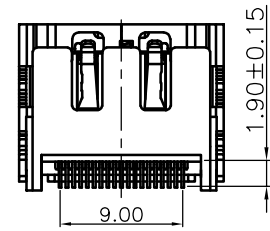
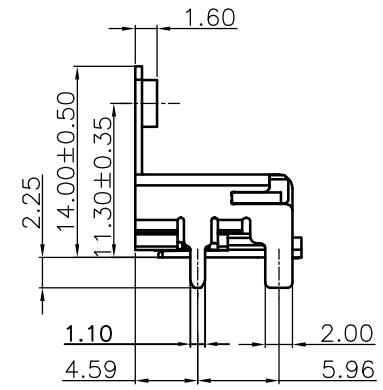
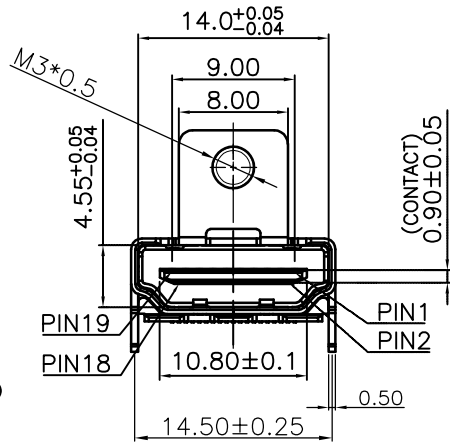
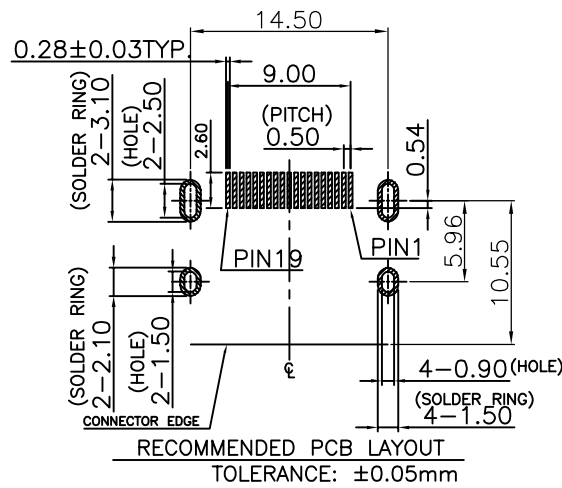
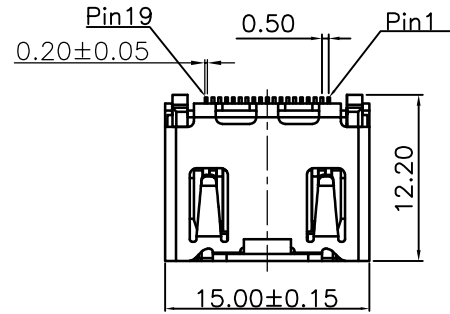

SPECIFICATIONS:

- ELECTRICAL CHARACTERISTICS
 - CURRENT RATING: 0.5 AMP
 - VOLTAGE RATING: 40 V
 - CONTACT RESISTANCE: 30MILLIOHMS MAX
 - INSULATION RESISTANCE: 100M MIN. @ 500V DC
 - DIELECTRIC WITHSTANDING VOLTAGE: 500V AC FOR 1 MINUTE
- MECHANICAL CHARACTERISTICS:
 - INSERTION FORCE : 4.5KGF MAX.
 - WITHDRAWING FORCE : 1KGF ~ 4KGF.
- LIFE TEST: 10000 CYCLES
- OPERATING TEMPERATURE: -25°C TO +85°C
- PART NO. DESCRIPTION:

PART NO. INFORMATION

HD01-A F X X 5 X - 003

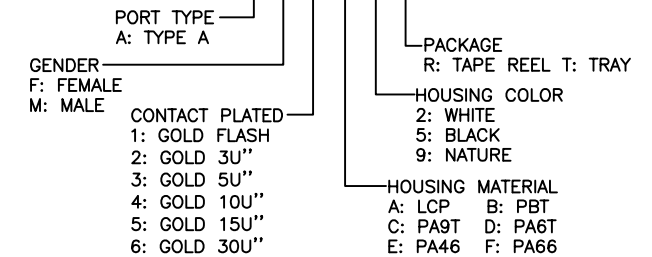

C	SHELL	1	C2680R-H Ni 50u" T=0.5mm PLATING ALL OVER
B	TERMINAL	19	Brass C2680-1/2H(HV120~140),T=0.2mm
A	HOUSING	1	LCP E130i UL94V-0 BLACK
NO	PART NAME	QTY	MATERIAL PLATING & COLOR

Bestcreate Technology Limited

REV: A UNIT mm SCALE 1=1 QUALITY SYMBOLS

TOLERANCES UNLESS OTHERWISE SPECIFIED:
 X. ± 0.50 X." ± 2.0"
 .X ± 0.20 .X" ± 1.5"
 .XX ± 0.15 .XX" ± 1.0"
 .XXX ± 0.05 .XXX" ± 0.5"
 Website: www.bsc-elec.com
 Email: bestcreate@bsc-elec.com

DESIGN: I.L DATE: 2017/7/5
 CHECKED: C.W DATE: 2017/7/5
 APPROVED: C.W DATE: 2017/7/5

TITLE: HDMI A FEMALE CONNECTOR SMT SCREW HEIGHT=11.3
 MATERILA: FINSH: DWG NO: HD01-AFXX5X-003
 PART NO: HD01-AFXX5X-003
 SIZE: A4
 SIZE: 1 OF 1