

RoHS Compliant

REVISIONS			
REV.	DESCRIPTION	DATE	DESIGN

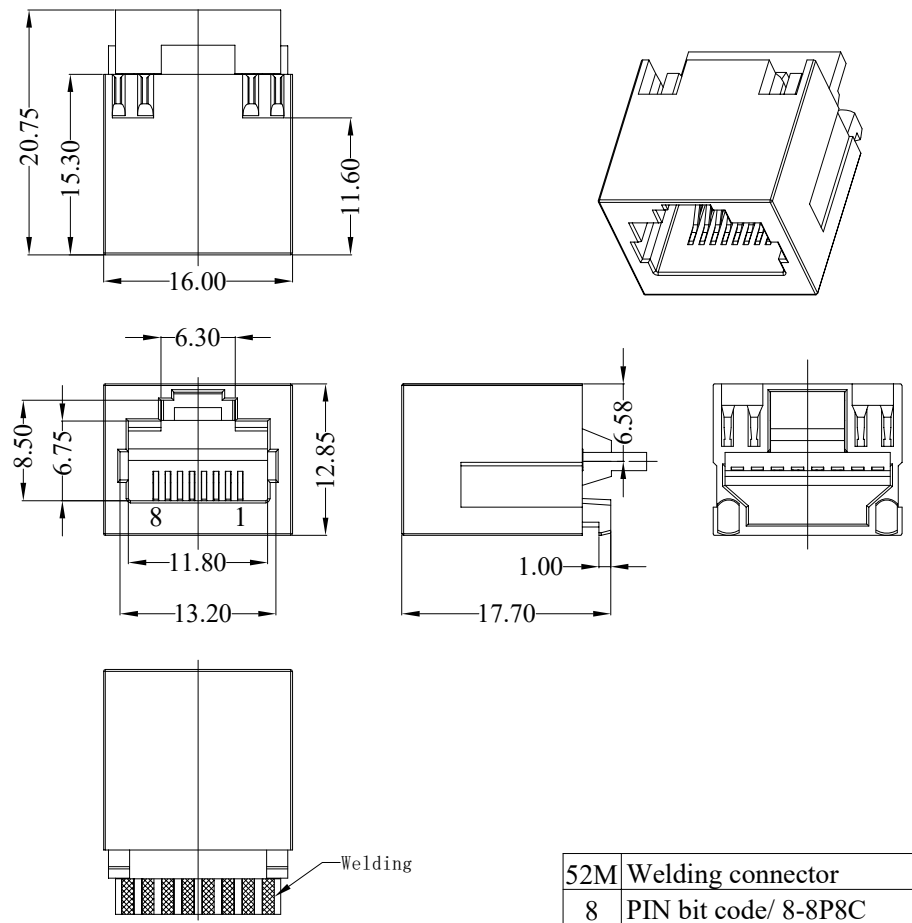

NOTES

MATERIAL

- 1.HOUSING MATERIAL : PBT UL94V-0
- 2.CONTACT MATERIAL : PHOSPHOR BRONZE T=0.3mm
- 3.PLATING : CONTACT AREA-SELECTIVE GOLD PLATING, TAILS PLATING TIN OVER NICKEL.

ELECTRICAL

- 1.VOLTAGE RATING : 125 VAC RMS.
- 2.CURRENT RATING : 1.5 AMP.
- 3.CONTACT RESISTANCE : 30 MILLIOHMS MAX.
- 4.INSULATION RESISTANCE : 500 MEGOHMS MIN @ 500V DC .
- 5.DIELECTRIC RESISTANCE : 1000V AC RMS 50Hz. 1MIN.

MECHANICAL

- 1.DURRABILITY : 750 CYCLES MIN.
- 2.PCB RETENTIONPRE-SOLDER : 1 LB MIN.

ENVIRONMENTAL:

- 1.STORAGE : -40°C ~ +85°C.
- 2.OPERATION : -20°C ~ +70°C.

PART NO. INFORMATION

RJ01- X 5 0 X - 080

CONTACT PLATED
 1: G/F 2: AU 3U"
 3: AU 6U" 4: AU 15U"
 5: AU 30U"
 PACKAGE
 R: TAPE REEL
 T: TRAY

52M	Welding connector
8	PIN bit code/ 8-8P8C
11	Window fixed code / 11-1X1
SX	Shape code /SX-all-plastic
X	LED fixed code/ X-No lights
1	Electroplate / 1-Au G/F u"
1	System identification code

TOLERANCES UNLESS OTHERWISE SPECIFIED:

.X	± 0.35	X.*	± 3'
.XX	± 0.25	.X*	± 2'
.XXX	± 0.15	.XX*	± 1'

Website: www.bsc-elec.com
 Email: bestcreate@bsc-elec.com

DESIGN:	DATE:	TITLE:	
I. L	2017. 3. 1	RJ45 180D 8P8C AF FOR WIRE SOLDERING	
CHECKED:	DATE:	MATERILA:	PART NO:
C. W	2017. 3. 1		RJ01-X50X-080
APPROVED:	DATE:	FINSH:	DWG NO:
C. W	2017. 3. 1		RJ01-X50X-080
		SIZE:	A4

Bestcreate Technology Limited

REV: A	UNIT mm	SCALE 1=1	QUALITY SYMBOLS
--------	---------	-----------	-----------------