

RoHS Compliant

REVISIONS			
REV.	DESCRIPTION	DATE	DESIGN

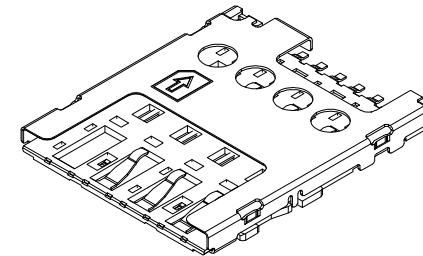
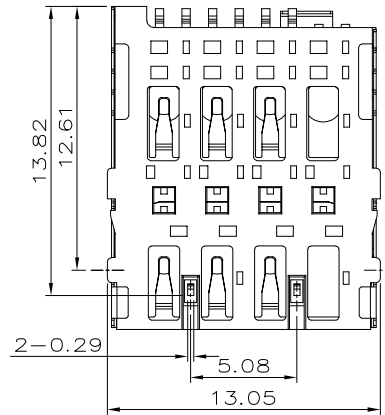
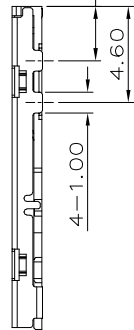
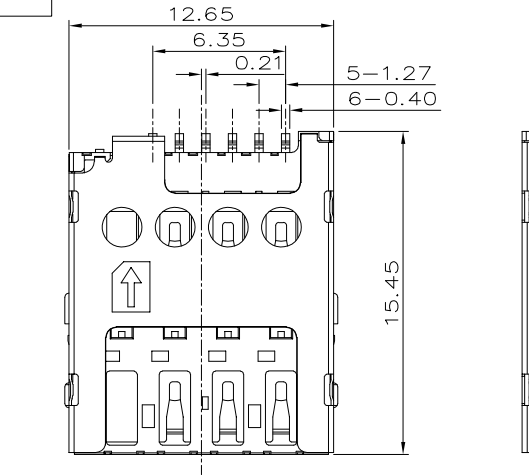

NOTES:
 1) MATERIAL
 HOUSING : LCP UL 94V-0
 CONTACT : C5210
 SHELL : SUS304
 2) FINISH :
 CONTACT: GOLD FLASH PLATED ON CONTACT AREA ;
 GOLD FLASH PLATING ON SOLDER TAILS ,
 WITH ENTIRE CONTACT UNDERPLATED NICKEL
 SHELL: NICKEL UNDERPLATED OVERALL ,
 GOLD FLASH PLATED ON SOLDER TAILS

3) ELECTRICAL SPECIFICATIONS:
 CURRENT RATING: 0.5A.
 VOLTAGE RATING: 5V.
 CONTACT RESISTANCE: 50 MILL. OHM MAX.
 INSULATION RESISTANCE: 1000 MEG. OHM MIN.
 4) MECHANICAL SPECIFICATIONS:
 DURABILITY: 3000 CYCLES MIN.

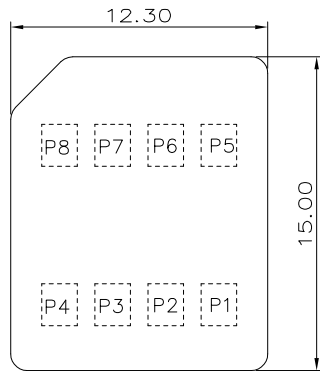
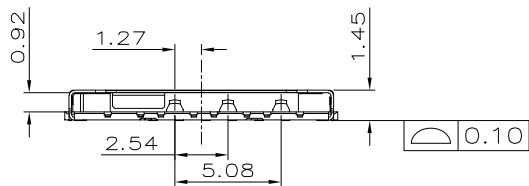

Pin1:VCC
 Pin2:RST
 Pin3:CLK
 Pin4:Reserved
 Pin5:GND
 Pin6:VPP
 Pin7:I/O
 Pin8:Reserved

MICRO. SIM CARD

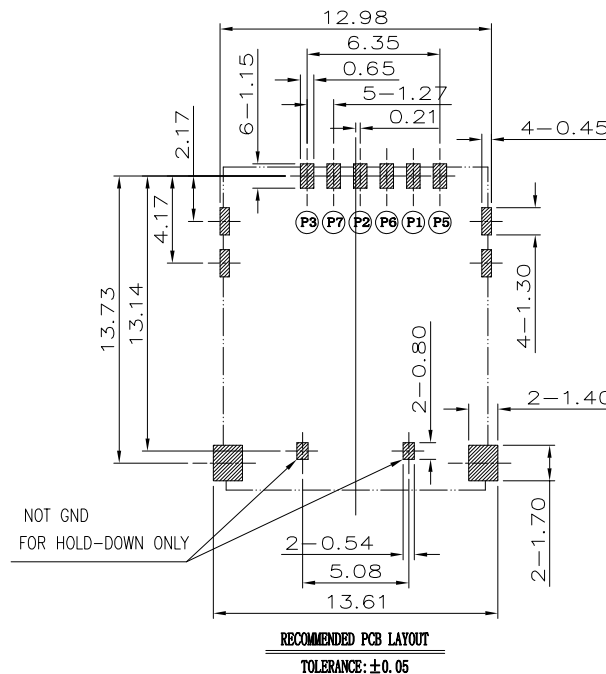

NOT GND
 FOR HOLD-DOWN ONLY

RECOMMENDED PCB LAYOUT
 TOLERANCE: ±0.05

PART NO. INFORMATION

MCSIM - 06 X X 5 R - 005

06:6P
 CONTACT PLATED
 1: GOLD FLASH
 2: GOLD 3U"
 3: GOLD 5U"
 4: GOLD 10U"
 5: GOLD 15U"
 6: GOLD 30U"
 PACKAGE
 R: TAPE REEL
 HOUSING COLOR
 2: WHITE
 5: BLACK
 9: NATURE
 HOUSING MATERIAL
 A: LCP B: PBT
 C: PA9T D: PA6T
 E: PA46 F: PA66

Bestcreate Technology Limited

TOLERANCES UNLESS OTHERWISE SPECIFIED:

.X	± 0.35	X'	± 5'
.XX	± 0.25	.X'	± 2'
.XXX	± 0.15	.XX'	± 1'

Website:www.bsc-elec.com
 Email:bestcreate@bsc-elec.com

DESIGN: I. L
 DATE: 2017. 3. 1
 CHECKED: C. W
 DATE: 2017. 3. 1
 APPROVED: C. W
 DATE: 2017. 3. 1

TITLE: 1. 45H, MICRO SIM CARD CONNECTOR
 MATERIAL: A4
 PART NO: MCSIM-06XX5R-005
 DWG NO: MCSIM-06XX5R-005
 SIZE: 1 OF 2

REV: A
 UNIT: mm
 SCALE: 1=1
 QUALITY SYMBOLS

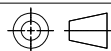

RoHS Compliant

〈图一〉



放料方向

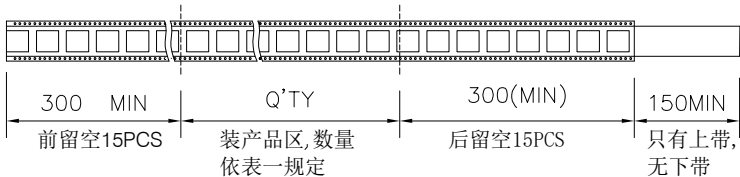

〈图二〉

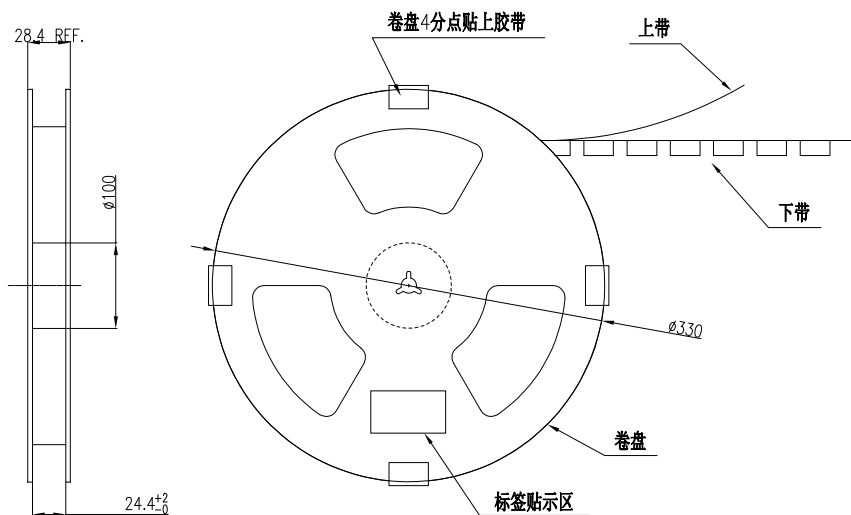

〈表一〉

PCS/卷	卷/箱	PCS/箱
1500	11	16500

〈图三〉

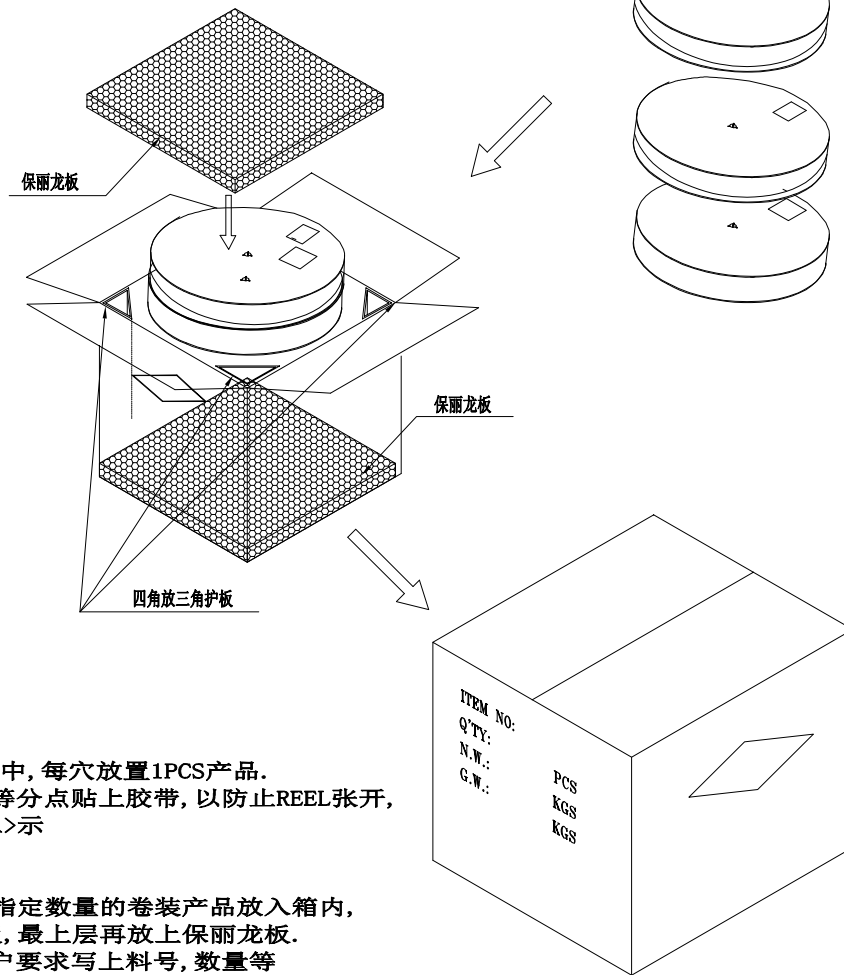

NOTE:

- 依〈图一〉示放置产品于下载中, 每穴放置1PCS产品.
- 包装机包好后, 在REEL的个等分点贴上胶带, 以防止REEL张开, 每REEL贴1PCS标签, 如〈图二〉示
- 包装数量见如〈表一〉示
- 包装成箱见如〈图三〉示
箱底放保丽龙板, 再依次将指定数量的卷装产品放入箱内, 四角分别放入四个三角护板, 最上层再放上保丽龙板.
- 封箱, 在封好的纸箱上按客户要求写上料号, 数量等
- 适用成品料号见如下〈表二〉

Bestcreate Technology Limited

TOLERANCES UNLESS OTHERWISE SPECIFIED:

.X	±	0.35	X'	±	5'
.XX	±	0.25	.X'	±	2'
.XXX	±	0.15	.XX'	±	1'

Website: www.bsc-elec.com
Email: bestcreate@bsc-elec.com

DESIGN:

I. L

CHECKED:

C. W

APPROVED:

C. W

DATE:

2017. 3. 1

DATE:

2017. 3. 1

DATE:

2017. 3. 1

TITLE:

1. 45H, MICRO SIM CARD CONNECTOR

MATERILA:

FINSH:

PART NO:

DWG NO:

MCSIM-06XX5R-005

MCSIM-06XX5R-005

SIZE:

A4
2 OF 2

REV: A

UNIT mm

SCALE 1=1

QUALITY SYMBOLS

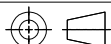

1

2

3

4

5

6

7

8