

RoHS Compliant

| REVISIONS | | | |
|-----------|-------------|------|--------|
| REV. | DESCRIPTION | DATE | DESIGN |
| | | | |

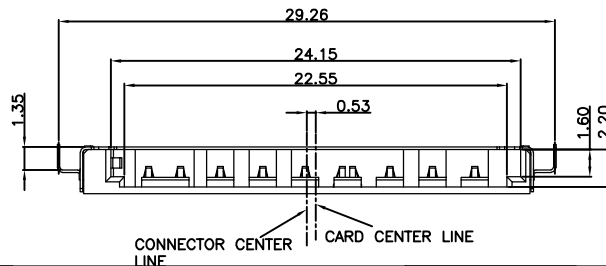
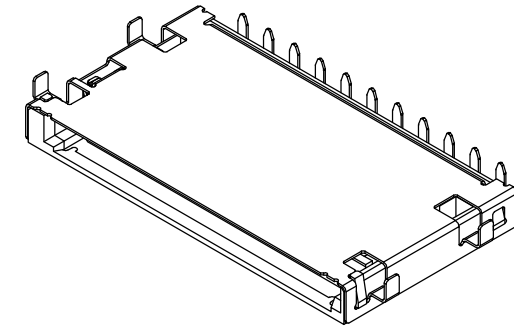
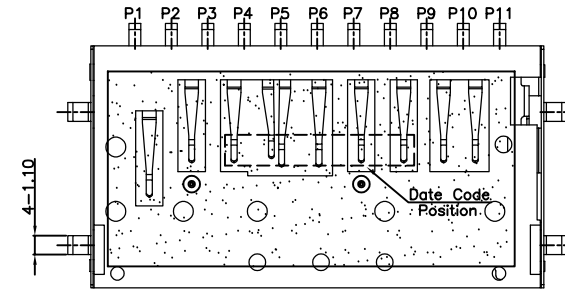
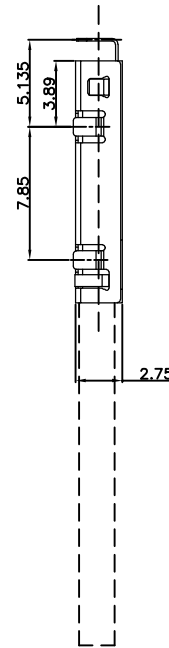
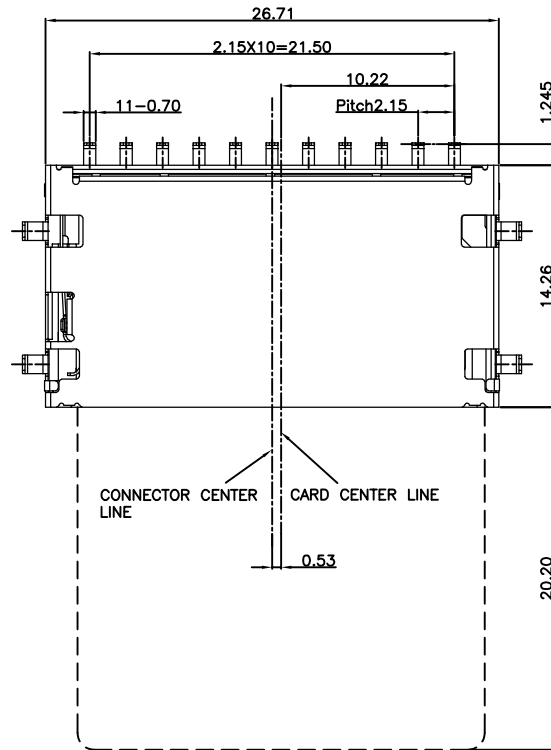
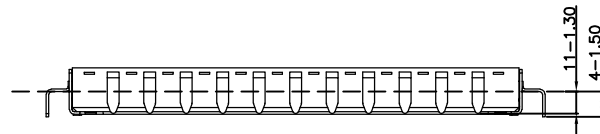

PART NO. INFORMATION

MSD - 10 X X 5 R - 011

- 11:1P
- CONTACT PLATED
- 1: GOLD FLASH
- 2: GOLD 3U"
- 3: GOLD 5U"
- 4: GOLD 10U"
- 5: GOLD 15U"
- 6: GOLD 30U"
- PACKAGE
- R: TAPE REEL
- HOUSING COLOR
- 2: WHITE
- 5: BLACK
- 9: NATURE
- HOUSING MATERIAL
- A: LCP B: PBT
- C: PA9T D: PA6T
- E: PA46 F: PA66

Bestcreate Technology Limited

TOLERANCES UNLESS OTHERWISE SPECIFIED:

| | | | |
|------|--------|------|------|
| .X | ± 0.35 | X.* | ± 5" |
| .XX | ± 0.25 | .X* | ± 2" |
| .XXX | ± 0.15 | .XX* | ± 1" |

Website: www.bsc-elec.com
Email: bestcreate@bsc-elec.com

DESIGN: I. L
DATE: 2017. 3. 1

CHECKED: C. W
DATE: 2017. 3. 1

APPROVED: C. W
DATE: 2017. 3. 1

TITLE: SD N/P BOTTOM CONTACT DIP MID MOUNT N/P 1.35

| | | |
|-------------|-------------------------|---------------|
| MATERIAL: A | PART NO: MSD-11XX5R-010 | SIZE: A4 |
| FINISH: C | DWG NO: MSD-11XX5R-010 | SHEET: 1 OF 3 |



| | | | |
|--------|---------|-----------|-----------------|
| REV: A | UNIT mm | SCALE 1=1 | QUALITY SYMBOLS |
|--------|---------|-----------|-----------------|

RoHS Compliant

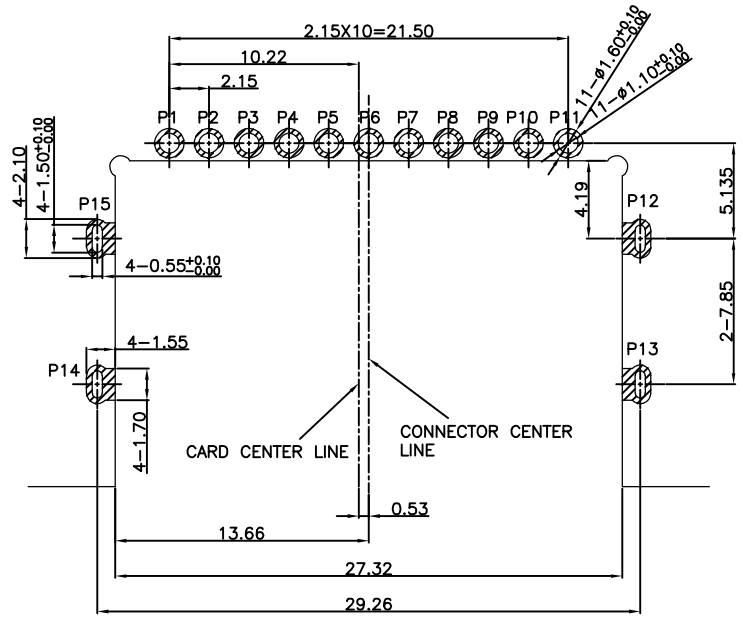
| REVISIONS | | | |
|-----------|-------------|------|--------|
| REV. | DESCRIPTION | DATE | DESIGN |
| | | | |



RECOMMEND P.C.B LAYOUT
TOLERANCE ±0.05

-  PAD
-  No trace , no test point, no via hole, no ground area

| WITHOUT CARD | | CARD INSERTED:LOCK | | CARD INSERTED:UNLOCK | |
|--------------|------------|--------------------|------------|----------------------|------------|
| W/P | GND | W/P | GND | W/P | GND |
| | | | | | |
| C/D | VSS1 P3 | C/D | VSS1 P3 | C/D | VSS1 P3 |
| | | | | | |

Specification

- *Electrical Characteristics:
Contact Current Rating:0.5 Amperes.
Dielectric Withstanding Voltage:AC500V r.m.s.
Insulation Resistance:1000 MΩ Minimum.
Contact Resistance:100 mΩ Maximum.
- *Environmental:
Operating Temperature:-25°C~+85°C.
- *Mechanical Characteristics:
Mating Cycles:10,000 Cycles Insertion/Extraction
Card Push Insertion/Out Force:1kgf Maximum.
Contact Retention Force:0.15kgf Minimum.
- *Material:
Insulator:HI-Temp Plastic UL 94V-0 Rated.
Contact:Copper Alloy.
Shell:Stainless Steel.

Pin Define

| Connector Pin No. | SD Card Pin No. | Pin Define |
|-------------------|-----------------|------------|
| P1 | P9 | DAT2 |
| P2 | P1 | DAT3 |
| P3 | P2 | CMD |
| P4 | | CD |
| P5 | P3 | VSS1 |
| P6 | P4 | VDD |
| P7 | P5 | CLK |
| P8 | P6 | VSS2 |
| P9 | P7 | DAT0 |
| P10 | P8 | DAT1 |
| P11 | | W/P |
| P12~P15 | | GND |

Bestcreate Technology Limited

TOLERANCES UNLESS OTHERWISE SPECIFIED:

| | | | |
|------|--------|------|------|
| .X | ± 0.35 | X' | ± 5' |
| .XX | ± 0.25 | .X' | ± 2' |
| .XXX | ± 0.15 | .XX' | ± 1' |

Website:www.bsc-elec.com
Email:bestcreate@bsc-elec.com

| | | | |
|-----------|-----|-------|----------|
| DESIGN: | I.L | DATE: | 2017.3.1 |
| CHECKED: | C.W | DATE: | 2017.3.1 |
| APPROVED: | C.W | DATE: | 2017.3.1 |

| | | |
|--|----------------------------|------------------|
| TITLE: SD N/P BOTTOM CONTACT DIP MID MOUNT N/P 1.35 | | |
| MATERILA: | PART NO: MSD-11XX5R-010 | SIZE: A4 |
| FINSH: | DWG NO: MSD-11XX5R-010 | SHEET: 2 OF 3 |

| | | | |
|--------|---------|-----------|-----------------|
| REV: A | UNIT mm | SCALE 1=1 | QUALITY SYMBOLS |
|--------|---------|-----------|-----------------|

RoHS Compliant

| REVISIONS | | | |
|-----------|-------------|------|--------|
| REV. | DESCRIPTION | DATE | DESIGN |
| | | | |

<图一>

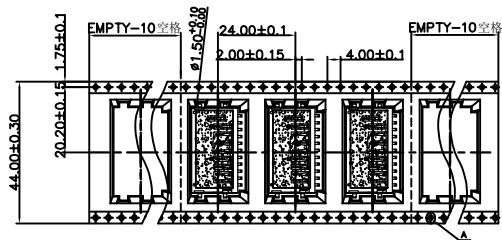

<TABLE 1> PACKAGING QUANTITY

| QTY/REEL | REEL/CARTON | QTY/CARTON |
|----------|-------------|------------|
| 600 | 6 | 3600 |

<图三>

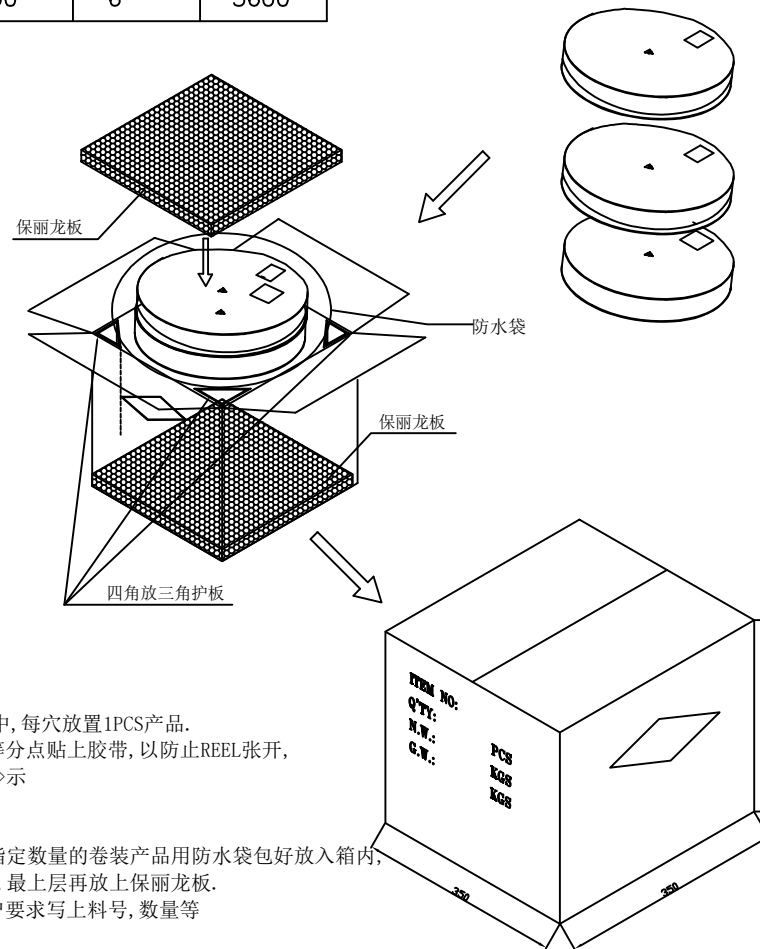

<图二>

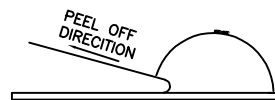
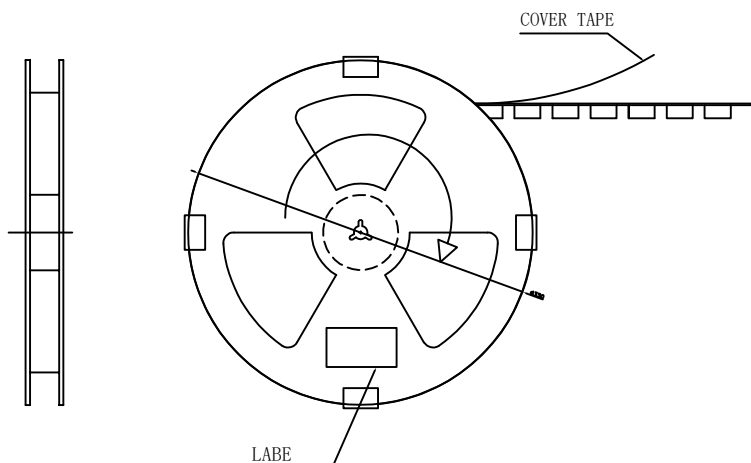
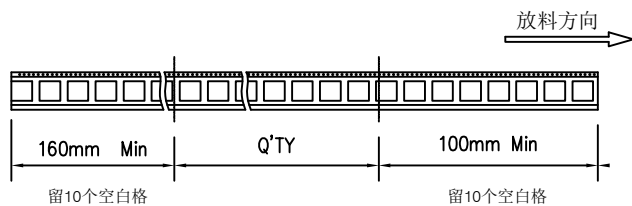

NOTE:

- 依<图一>示放置产品于下载中, 每穴放置1PCS产品.
- 包装机包好后, 在REEL的个等分点贴上胶带, 以防止REEL张开, 每REEL贴1PCS标签, 如<图二>示
- 包装数量见如<TABLE 1>示
- 包装成箱见如<图三>示
箱底放保利龙板, 再依次将指定数量的卷装产品用防水袋包好放入箱内, 四角分别放入四个三角护板, 最上层再放上保利龙板.
- 封箱, 在封好的纸箱上按客户要求写上料号, 数量等

Bestcreate Technology Limited

TOLERANCES UNLESS OTHERWISE SPECIFIED:

| | | | |
|------|--------|------|------|
| .X | ± 0.35 | X' | ± 5' |
| .XX | ± 0.25 | .X' | ± 2' |
| .XXX | ± 0.15 | .XX' | ± 1' |

Website: www.bsc-elec.com

Email: bestcreate@bsc-elec.com

DESIGN: I.L DATE: 2017.3.1

CHECKED: C.W DATE: 2017.3.1

APPROVED: C.W DATE: 2017.3.1

TITLE: SD N/P BOTTOM CONTACT DIP MID MOUNT N/P 1.35

MATERILA: PART NO: MSD-11XX5R-010 SIZE: A4

FINISH: DWG NO: MSD-11XX5R-010 SHEET: 3 OF 3

REV: A UNIT mm SCALE 1=1 QUALITY SYMBOLS