

RoHS Compliant

REVISIONS			
REV.	DESCRIPTION	DATE	DESIGN

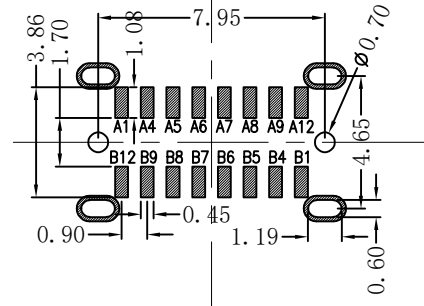

- 一、 Raw materials:
 1. Plastic: UL 94V-0 LCP black
 2. Terminal: 0.15 thick copper alloy C2680/C7025
 3. Shell: Stainless steel 201/304
 4. Hook: Stainless steel 201/304
- 二、 Electroplating:
 1. Terminal: Half gold glossy tin 1u"
 2. Shell: Nickel plated
- 三、 Mechanical performance:
 - Insertion force: 5-20N
 - Pullout force: 8-20N before life test, 5-20N after life test
 - Durable to plug and unplug: 500 times/H, 10000 times
 - Working temperature: 0 °C~+50 °C
 - Storage temperature: -20 °C~+60 °C
- 四、 Electrical performance:
 - Rated current: C2680/3A; C7025/5A
 - Contact impedance: Before life testing: 40 MΩ MAX, after life test: 50 MΩ MAX
 - High voltage resistance: 100V AC for 1 minute Min
 - No breakdown, no arc
 - Insulation impedance: 100 M MIN
- 五、 Environmental performance:
 - Environmental protection: The product meets ROHS requirements
 - Salt spray test: temperature 35 ± 2 °C,
 - Humidity: 95-98%;
 - PH value: 6.5-7.2,
 - 48H gold-plated area, 24H nickel plated area
 - Welding process: It is recommended to use reflow soldering,
 - Temperature resistance of 260 degrees, 8S

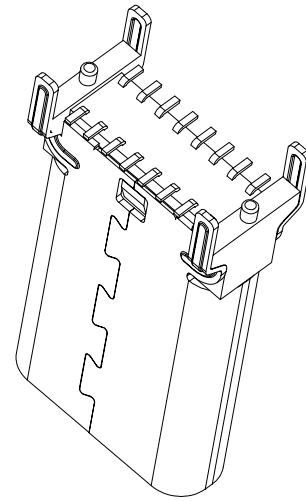
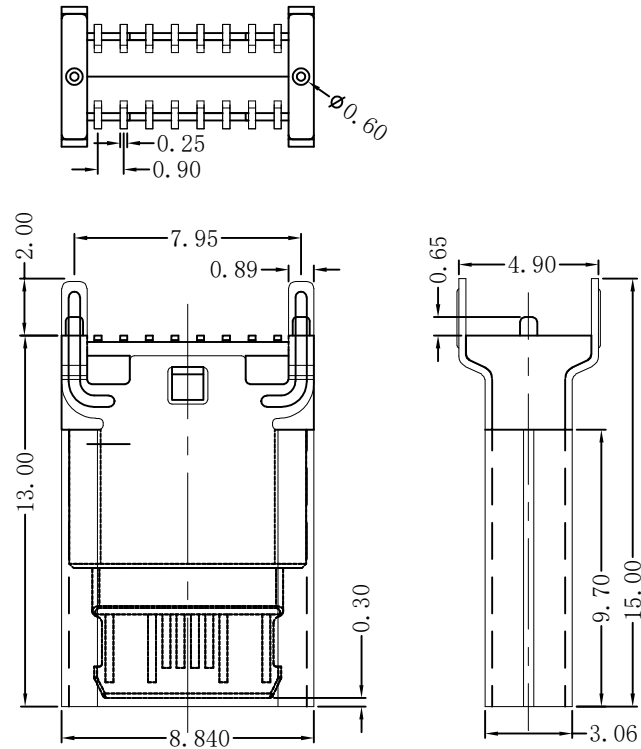
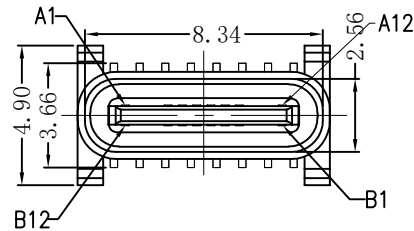

PART NO. INFORMATION

U06-C F X X 5 R - 085-V1

- PORT TYPE
C: TYPE C
- PACKAGE
R: TAPE REEL
- HOUSING COLOR
2: WHITE
5: BLACK
9: NATURE
- HOUSING MATERIAL
A: LCP B: PBT
C: PA9T D: PA6T
E: PA46 F: PA66
- CONTACT PLATED
1: GOLD FLASH
2: GOLD 5U"
3: GOLD 6U"
4: GOLD 10U"
5: GOLD 15U"
6: GOLD 30U"
- GENDER
F: FEMALE
M: MALE

A1	GN	B12	GN
A4	VBUS	B9	VBUS
A5	CC1	B8	SHIELD
A6	DP1	B7	SHIELD
A7	DML	B6	DP2
A8	SHIELD	B5	CC2
A9	VBUS	B4	VBUS
A12	GN	B1	GN
FIN	SIGNAL NAME	FIN	SIGNAL NAME

Bestcreate Technology Limited

TOLERANCES UNLESS OTHERWISE SPECIFIED:

.X	± 0.30	X.*	± 5*
.XX	± 0.15	.X*	± 2*
.XXX	± 0.10	.XX*	± 1*

DESIGN:	DATE:
I. L	
CHECKED:	DATE:
C. W	
APPROVED:	DATE:
C. W	

TITLE: TYPE-C FEMALE 16P VERTICAL SMT 13.0H		
MATERIAL:	PART NO: U06-CFXX5R-085-V1	SIZE: A4
FINISH:	DWG NO: U06-CFXX5R-085-V1	1 OF 1

REV: A	UNIT mm	SCALE 1=1	QUALITY SYMBOLS
-----------	------------	--------------	-----------------

Website: www.bsc-elec.com
Email: bestcreate@bsc-elec.com